

A large green stylized plug icon on the left side of the page, partially overlapping the main title.

ELECTRICITY NORTH WEST

Use of System Charging Statement

FINAL NOTICE

Effective from 1st April 2015

Version 1.0

304 Bridgewater Place
Birchwood Park
Warrington
Cheshire
WA3 6XG
Registered no: 2366949 (England)

Version Control

Version	Date	Description of version and any changes made
V1.0	December 2014	Based on template issued on 25-Nov-14. Includes Final charges effective from 2015.

A change-marked version of this statement can be provided upon request.

Contents

1. Introduction	5
Validity period	6
Contact details	6
2. Charge application and definitions	7
Supercustomer billing and payment	7
Supercustomer charges	8
Site-specific billing and payment	9
Site-specific billed charges	9
Time periods for half-hourly metered properties	10
Time periods for half-hourly unmetered properties	11
Application of capacity charges	11
Chargeable capacity	11
Exceeded capacity	12
Demand exceeded capacity	12
Generation exceeded capacity	12
Standby capacity for additional security on site	13
Minimum capacity levels	13
Application of charges for excess reactive power	13
Demand chargeable reactive power	13
Generation chargeable reactive power	14
Incorrectly allocated charges	14
Generation charges for pre-2005 Designated EHV Properties	16
Provision of billing data	16
Out of area use of system charges	17
Licensed distribution network operator charges	17
Exempt Distribution Networks	17
Full settlement metering	18
Difference metering	18
3. Schedule of charges for use of the distribution system	19
4. Schedule of line loss factors	20
Role of line loss factors in the supply of electricity	20
Calculation of line loss factors	20
Line loss factor time periods	21
Line loss factor tables	21
5. Notes for Designated EHV Properties	22
EDCM nodal costs	22
Charges for new Designated EHV Properties	22
Charges for amended Designated EHV Properties	22
Demand-side management	23
6. Electricity distribution rebates	24
7. Accounting and administration services	24
8. Charges for electrical plant provided ancillary to the grant of use of system	24
Appendix 1 - Glossary	25
Appendix 2 - Guidance notes	31
Background	31
Meter point administration	31
Your charges	33
Reducing your charges	33
Reactive power and reactive power charges	34
Site-specific EDCM charges	34

Annex 1 - Schedule of charges for use of the distribution system by LV and HV Designated Properties

Annex 2 - Schedule of charges for use of the distribution system by Designated EHV Properties (including LDNOs with Designated EHV Properties/end-users)

Annex 3 - Schedule of charges for use of the distribution system by preserved/additional LLF classes

Annex 4 - Charges applied to LDNOs with LV and HV end-users

Annex 5 - Schedule of line loss factors

Annex 6 - Addendum to charging statement detailing charges for new Designated EHV Properties

1. Introduction

- 1.1. This statement tells you about our charges and the reasons behind them. It has been prepared consistent with Standard Licence Condition 14 of our Electricity Distribution Licence. The main purpose of this statement is to provide our schedule of charges¹ for the use of our Distribution System and to provide the schedule of adjustment factors² that should be applied in Settlement to account for losses from the Distribution System. We have also included guidance notes in Appendix 2 to help improve your understanding of the charges we apply.
- 1.2. Within this statement we use terms such as 'Users' and 'Customers' as well as other terms which are identified with initial capitalisation. These terms are defined in the glossary.
- 1.3. The charges in this statement are calculated using the Common Distribution Charging Methodology (CDCM) for Low Voltage and High Voltage (LV and HV) Designated Properties and the Extra-high Voltage (EHV) Distribution Charging Methodology (EDCM) for Designated EHV Properties.
- 1.4. Separate charges are calculated depending on the characteristics of the connection and whether the use of the Distribution System is for demand or generation purposes. Where a generation connection is seen to support the Distribution System the charges will be negative and the Supplier will receive credits for exported energy.
- 1.5. The application of charges to premises can usually be referenced using the Line Loss Factor Class (LLFC) contained in the charge tables. Further information on how to identify and calculate the charge that will apply for your premise is provided in the guidance notes in Appendix 2.
- 1.6. All charges in this statement are shown **exclusive** of VAT. Invoices will include VAT at the applicable rate.
- 1.7. The annexes that form part of this statement are also available in spreadsheet format. This spreadsheet contains supplementary information used for charging purposes and a simple model to assist you to calculate charges. This spreadsheet can be downloaded from <http://www.enwl.co.uk/our-services/use-of-system-charges> .

¹ Charges can be positive or negative.

² Also known as Loss Adjustment Factors or Line Loss Factors

Validity period

- 1.8. This charging statement is valid for services provided from the effective date stated on the front of the statement and remains valid until updated by a revised version or superseded by a statement with a later effective date.
- 1.9. When using this charging statement care should be taken to ensure that the statement or statements covering the period that is of interest are used.
- 1.10. Notice of any revision to the statement will be provided to Users of our Distribution System. The latest statements can be downloaded from <http://www.enwl.co.uk/our-services/use-of-system-charges>.

Contact details

- 1.11. If you have any questions about this statement please contact us at the address shown below:

Charging Manager
Electricity North West
304 Bridgewater Place
Birchwood Park
Warrington
WA3 6XG
Email: electricitycommercialpolicy@enwl.co.uk
Telephone: 08433114323

- 1.12. All enquiries regarding connection agreements and changes to maximum capacities should be addressed to:

Data Assurance Manager
Electricity North West
Hartington Road
Preston
PR1 8LE
Email: terms&conditions@enwl.co.uk
Telephone: 08433114503

- 1.13. For all other queries please contact our Customer Contact Centre:

Electricity North West

PO Box 218

Warrington

WA3 6XG

Email: enquiries@enwl.co.uk

Telephone: 0800 195 4141; lines are open 24 hours, 365 days per year

2. Charge application and definitions

- 2.1. The following section details how the charges in this statement are applied and billed to Users of our Distribution System.
- 2.2. We utilise two billing approaches depending on the type of metering data received. The 'Supercustomer' approach is used for Non-Half-Hourly (NHH) metered, NHH unmetered or aggregated Half-Hourly (HH) metered premises and the 'Site-specific' approach is used for HH metered or pseudo HH unmetered premises.
- 2.3. Typically NHH metered are domestic and small businesses, HH metered are larger businesses and unmetered premises are normally streetlights.

Supercustomer billing and payment

- 2.4. Supercustomer billing and payment applies to metering points registered as NHH metered, NHH unmetered or aggregated HH metered. The Supercustomer approach makes use of aggregated data obtained from Suppliers using the 'Non Half Hourly Distribution Use of System (DUoS) Report' data flow.
- 2.5. Invoices are calculated on a periodic basis and sent to each User for whom we transport electricity through our distribution system. Invoices are reconciled over a period of approximately 14 months to reflect later and more accurate consumption figures.
- 2.6. The charges are applied on the basis of the LLFC assigned to a Meter Point Administration Number (MPAN), and the units consumed within the time periods specified in this statement. These time periods may not necessarily be the same as those indicated by the Time Pattern Regimes (TPRs) assigned to the Standard Settlement Configuration (SSC). All LLFCs are assigned at our sole discretion.

Supercustomer charges

- 2.7. Supercustomer charges include the following components:
- a fixed charge - pence/MPAN/day; there will be only one fixed charge applied to each MPAN; and
 - unit charges, pence/kWh; more than one unit charge may apply depending on the type of tariff for which the MPAN is registered.
- 2.8. Users who supply electricity to a Customer whose metering system is:
- Measurement Class A or B, and settled on Profile Classes (PC) 1 through to 8;
- or
- Measurement Class F or G;
- will be allocated the relevant charge structure set out in Annex 1.
- 2.9. Measurement Class A charges apply to Exit/Entry Points where NHH metering is used for Settlement.
- 2.10. Measurement Class B charges apply to Exit Points deemed to be suitable as Unmetered Supplies as permitted in the Electricity (Unmetered Supply) Regulations 2001³ and where operated in accordance with Balancing and Settlement Code (BSC) procedure 520⁴.
- 2.11. Measurement Class F and G charges apply to Exit/Entry Points where HH aggregated metering data is used for Settlement.
- 2.12. Identification of the appropriate charge can be made by cross-reference to the LLFC.
- 2.13. Valid Settlement PC/SSC/Meter Timeswitch Code (MTC) combinations for LLFCs where the Metering System is Measurement Class A and B are detailed in Market Domain Data (MDD).
- 2.14. Where an MPAN has an invalid Settlement combination, the 'Domestic Unrestricted' fixed and unit charges will be applied as default until the invalid combination is corrected. Where there are multiple SSC/TPR combinations,

³ The Electricity (Unmetered Supply) Regulations 2001 available from <http://www.legislation.gov.uk/uksi/2001/3263/made>

⁴ Balancing and Settlement Code Procedures on unmetered supplies are available from <http://www.elexon.co.uk/pages/bscps.aspx>

the default 'Domestic Unrestricted' fixed and unit charges will be applied for each invalid TPR combination.

- 2.15. The time periods for unit charges where the Metering System is Measurement Class A and B are as specified by the SSC. To determine the appropriate charge rate for each SSC/TPR a lookup table is provided in the spread sheet that accompanies this statement⁵.
- 2.16. The time periods for unit charges where the Metering System is Measurement Class F and G are set out in the table 'Time Bands for Half Hourly metered Properties' in Annex 1.
- 2.17. The 'Domestic Off-Peak' and 'Small Non-Domestic Off-Peak' charges are additional to either an unrestricted or a two-rate charge.

Site-specific billing and payment

- 2.18. Site-specific billing and payment applies to Measurement Class C, D and E metering points settled as HH metered. The site-specific billing and payment approach to Use of System (UoS) billing makes use of HH metering data at premise level received through Settlement.
- 2.19. Invoices are calculated on a periodic basis and sent to each User for whom we transport electricity through our Distribution System. Where an account is based on estimated data, the account shall be subject to any adjustment that may be necessary following the receipt of actual data from the User.
- 2.20. The charges are applied on the basis of the LLFCs assigned to the MPAN (or the Meter System Identifier (MSID) for Central Volume Allocation (CVA) sites), and the units consumed within the time periods specified in this statement.
- 2.21. All LLFCs are assigned at our sole discretion.

Site-specific billed charges

- 2.22. Site-specific billed charges may include the following components:
- a fixed charge pence/MPAN/day or pence/MSID/day;
 - a capacity charge, pence/kVA/day, for Maximum Import Capacity (MIC) and/or Maximum Export Capacity (MEC);

⁵ ENWL - Schedule of charges and other tables – Version 0.6.xlsx

- an excess capacity charge, pence/kVA/day, if a site exceeds its MIC and/or MEC;
 - unit charges, pence/kWh, more than one unit charge may be applied;
- and
- an excess reactive power charge, pence/kVArh, for each unit in excess of the reactive charge threshold.
- 2.23. Users who wish to supply electricity to customers whose metering system is Measurement Class C, D or E or CVA will be allocated the relevant charge structure dependent upon the voltage and location of the metering point.
- 2.24. Measurement Class C, E or CVA charges apply to Exit/Entry Points where HH metering, or an equivalent meter, is used for Settlement purposes.
- 2.25. Measurement Class D charges apply to Exit points deemed to be suitable as Unmetered Supplies as permitted in the Electricity (Unmetered Supply) Regulations 2001⁶ and where operated in accordance with BSC procedure 520⁷.
- 2.26. Fixed charges are generally levied on a pence per MPAN/MSID basis. Where two or more HH MPANs are located at the same point of connection (as identified in the connection agreement), with the same LLFC, and registered to the same supplier, only one daily fixed charge will be applied.
- 2.27. LV and HV Designated Properties will be charged in accordance with the CDCM and allocated the relevant charge structure set out in Annex 1.
- 2.28. Designated EHV Properties will be charged in accordance with the EDCM and allocated the relevant charge structure set out in Annex 2.
- 2.29. Where LV and HV Designated Properties or Designated EHV Properties have more than one point of connection (as identified in the Connection Agreement) then separate charges will be applied to each point of connection.

Time periods for half-hourly metered properties

- 2.30. The time periods for the application of unit charges to LV and HV Designated Properties that are HH metered are detailed in Annex 1. In December 2013, we

⁶ The Electricity (Unmetered Supply) Regulations 2001 available from <http://www.legislation.gov.uk/ukxi/2001/3263/made>

⁷ Balancing and Settlement Code Procedures on unmetered supplies and available from <http://www.elexon.co.uk/pages/bscps.aspx>

issued a 15 month notice to change the time bands. The new time bands will be effective from 01 April 2015 and details of the new time bands are set out in Annex 1.

- 2.31. The time periods for the application of unit charges to Designated EHV Properties are detailed in Annex 2. In December 2013, we issued a 15 month notice to change the time bands. The new time bands will be effective from 01 April 2015 and details of the new time bands are set out in Annex 2.

Time periods for pseudo half-hourly unmetered properties

- 2.32. The time periods for the application of unit charges to connections that are pseudo HH metered are detailed in Annex 1. In December 2013, we issued a 15 month notice to change the time bands. The new time bands will be effective from 01 April 2015 and details of the new time bands are set out in Annex 1.

Application of capacity charges

- 2.33. The following sections explain the application of capacity charges and exceeded capacity charges.

Chargeable capacity

- 2.34. The chargeable capacity is, for each billing period, the MIC/MEC, as detailed below.
- 2.35. The MIC/MEC will be agreed with us at the time of connection or pursuant to a later change in requirements. Following such an agreement (be it at the time of connection or later) no reduction in MIC/MEC will be allowed for a period of one year.
- 2.36. Reductions to the MIC/MEC may only be permitted once in a 12 month period. Where MIC/MEC is reduced the new lower level will be agreed with reference to the level of the customer's maximum demand. The new MIC/MEC will be applied from the start of the next billing period after the date that the request was received. It should be noted that, where a new lower level is agreed, the original capacity may not be available in the future without the need for network reinforcement and associated charges.
- 2.37. In the absence of an agreement, the chargeable capacity, save for error or omission, will be based on the last MIC and/or MEC previously agreed by the distributor for the relevant premise's connection. A customer can seek to agree

or vary the MIC and/or MEC by contacting us using the contact details in section 1.

Exceeded capacity

2.38. Where a customer takes additional unauthorised capacity over and above the MIC/MEC, the excess will be classed as exceeded capacity. The exceeded portion of the capacity will be charged at the excess capacity charge p/kVA/day rate, based on the difference between the MIC/MEC and the actual capacity used. This will be charged for the full duration of the month in which the breach occurs.

Demand exceeded capacity

$$\text{Demandexceeded capacity} = \max(2 \times \sqrt{AI^2 + \max(RI, RE)^2} - MIC, 0)$$

Where:

AI = Active Import (kWh)

RI = Reactive import (kVArh)

RE = Reactive export (kVArh)

MIC = Maximum import capacity (kVA)

2.39. Only reactive import and reactive export values occurring at times of active import are used in the calculation.

2.40. This calculation is completed for every half hour and the maximum value from the billing period is applied.

Generation exceeded capacity

$$\text{Generationexceeded capacity} = \max(2 \times \sqrt{AE^2 + \max(RI, RE)^2} - MEC, 0)$$

Where:

AE = Active Export (kWh)

RI = Reactive import (kVArh)

RE = Reactive export (kVArh)

MEC = Maximum export capacity (kVA)

2.41. Only reactive import and reactive export values occurring at times of active export are used in the calculation.

2.42. This calculation is completed for every half hour and the maximum value from the billing period is applied.

Standby capacity for additional security on site

2.43. Where standby capacity charges are applied, the charge will be set at the same rate as that applied to normal MIC. Where, at the customer’s request, for additional security of supplies requiring sterilisation of capacity at two different sources of supply, we reserve the right to charge for the capacity held at each source.

Minimum capacity levels

2.44. There is no minimum capacity threshold.

Application of charges for excess reactive power

2.45. When an individual HH metered MPAN’s reactive power (measured in kVArh) at LV and HV Designated Properties exceeds 33% of total active power (measured in kWh), excess reactive power charges will apply. This threshold is equivalent to an average power factor of 0.95 during the period. Any reactive units in excess of the 33% threshold are charged at the rate appropriate to the particular charge.

2.46. Power Factor is calculated as follows:

Cos θ = Power Factor

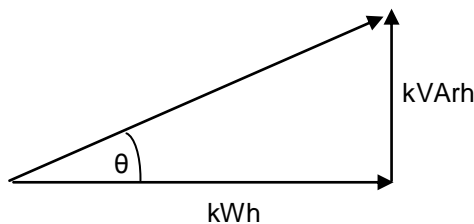

2.47. The chargeable reactive power is calculated as follows:

Demand chargeable reactive power

$$\text{DemandchargeablekVArh} = \max \left(\max(RI, RE) - \left(\sqrt{\left(\frac{1}{0.95^2} - 1 \right)} \times AI \right), 0 \right)$$

Where:

AI = Active import (kWh)

RI = Reactive import (kVArh)

RE = Reactive export (kVArh)

- 2.48. Only reactive import and reactive export values occurring at times of active import are used in the calculation.
- 2.49. The square root calculation will be to two decimal places.
- 2.50. This calculation is completed for every half hour and the values summated over the billing period.

Generation chargeable reactive power

$$\text{Generation chargeable kVArh} = \max\left(\max(RI, RE) - \left(\sqrt{\left(\frac{1}{0.95^2} - 1\right)} \times AE\right), 0\right)$$

Where:

AE = Active Export (kWh)

RI = Reactive Import (kVArh)

RE = Reactive Export (kVArh)

- 2.51. Only reactive import and reactive export values occurring at times of active export are used in the calculation.
- 2.52. The square root calculation will be to two decimal places.
- 2.53. This calculation is completed for every half hour and the values summated over the billing period.

Incorrectly allocated charges

- 2.54. It is our responsibility to apply the correct charges to each MPAN/MSID. The allocation of charges is based on the voltage of connection and metering information. We are responsible for deciding the voltage of connection while the Supplier determines and provides the metering information.
- 2.55. Generally, the voltage of connection is determined by where the metering is located and where responsibility for the electrical equipment transfers from us to the connected customer. This is normally established when the MPAN/MSID is created and will include information about whether the MPAN/MSID is for import or export purposes. Where an MPAN/MSID is used for export purposes the type of generation (intermittent or non-intermittent) will also be determined.

- 2.56. The Supplier provides us with metering information which enables us to allocate charges where there is more than one charge per voltage level. This metering data is likely to change over time if, for example, a Supplier changes from a two rate meter to a single rate meter. When this happens we will change the allocation of charges accordingly.
- 2.57. Where it has been identified that a charge is likely to be incorrectly allocated due to the wrong voltage of connection (or import/export details) then a correction request must be made to us. Requests from persons other than the current Supplier must be accompanied by a Letter of Authority from the Customer; the existing Supplier must also be informed. Any request must be supported by an explanation of why it is believed that the current charge is wrongly applied along with supporting information, including, where appropriate photographs of metering positions or system diagrams. Any request to correct the current charge that also includes a request to backdate the correction must include justification as to why it is considered appropriate to backdate the change.
- 2.58. If it has been identified that a charge has been incorrectly allocated due to the metering data then a correction request should be made to the Supplier.
- 2.59. Where we agree that an MPAN/MSID has been assigned to the wrong voltage level then we will correct it by allocating the correct set of charges for that voltage level. Any adjustment for incorrectly applied charges will be as follows:
- Any credit or additional charge will be issued to the Supplier/s who were effective during the period of the change.
 - The correction will be applied from the date of the request, back to the date of the incorrect allocation or, up to the maximum period specified by; the Limitation Act (1980), in England and Wales, which covers a six year period and the Prescription and Limitation (Scotland) Act 1973, which covers a five year period; whichever is the shorter.
- 2.60. Should we reject the request a justification will be provided to the requesting Party.
- 2.61. We shall not unreasonably withhold or delay any agreement to correct the charges applied and would expect to reach agreement within three months from the date of request.

Generation charges for pre-2005 designated EHV properties

2.62. Designated EHV Properties that were connected to the distribution system under a pre-2005 connection charging policy are eligible for exemption from UoS charges for generation unless one of the following criteria has been met:

- 25 years have passed since their first energisation/connection date (i.e. Designated EHV Properties with connection agreements dated prior to 1st April 2005, and for which 25 years has passed since their first energisation/connection date will receive use of system charges for generation from the next charging year following the expiry of their 25 years exemption, (starting 1st April), or
- the person responsible for the Designated EHV Property has provided notice to us that they wish to opt in to UoS charges for generation.

If a notice to opt in has been provided there will be no further opportunity to opt out.

2.63. Furthermore, if an exempt customer makes an alteration to its export requirement then the customer may be eligible to be charged for the additional capacity required or energy imported or exported. For example, where a generator increases its export capacity the incremental increase in export capacity will attract UoS charges as with other non-exempt generators.

Provision of billing data

2.64. Where HH metering data is required for UoS charging and this is not provided in accordance with the BSC or the Distribution Connection and Use of System Agreement (DCUSA), such metering data shall be provided to us by the User of the system in respect of each calendar month within five working days of the end of that calendar month.

2.65. The metering data shall identify the amount consumed and/or produced in each half hour of each day and shall separately identify active and reactive import and export. Metering data provided to us shall be consistent with that received through the metering equipment installed.

2.66. Metering data shall be provided in an electronic format specified by us from time to time and, in the absence of such specification, metering data shall be provided in a comma-separated text file in the format of Master Registration

Agreement (MRA) data flow D0275 (as agreed with us). The data shall be emailed to DUOS.Billing@enwl.co.uk.

2.67. We require details of reactive power imported or exported to be provided for all Measurement Class C and E sites. It is also required for CVA sites and Exempt Distribution Network boundaries with difference metering. We reserve the right to levy a charge on Users who fail to provide such reactive data. In order to estimate missing reactive data, a power factor of 0.9 lag will be applied to the active consumption in any half hour.

Out of area use of system charges

2.68. We do not operate networks outside our Distribution Service Area.

Licensed distribution network operator charges

2.69. Licensed Distribution Network Operator (LDNO) charges are applied to LDNOs who operate Embedded Networks within our Distribution Service Area.

2.70. The charge structure for LV and HV Designated Properties embedded in networks operated by LDNOs will mirror the structure of the All-the-way Charge and is dependent upon the voltage of connection of each embedded network to the host DNO's network. The same charge elements will apply as those that match the LDNO's end customer charges. The relevant charge structures are set out in Annex 4.

2.71. Where an MPAN has an invalid Settlement combination, the 'LDNO HV: Domestic Unrestricted' fixed and unit charges will be applied as default until the invalid combination is corrected. Where there are multiple SSC/TPR combinations, the default 'LDNO HV: Domestic Unrestricted' fixed and unit charges will be applied for each invalid TPR combination.

2.72. The charge structure for Designated EHV Properties embedded in networks operated by LDNOs will be calculated individually using the EDCM. The relevant charge structures are set out in Annex 2.

2.73. For Nested Networks the relevant charging principles set out in DCUSA Schedule 21 will apply.

Licence exempt distribution networks

2.74. The Electricity and Gas (Internal Market) Regulations 2011 introduced new obligations on owners of licence exempt distribution networks (sometimes

called private networks) including a duty to facilitate access to electricity and gas suppliers for customers within those networks.

- 2.75. When customers (both domestic and commercial) are located within an exempt distribution network and require the ability to choose their own supplier this is called 'third party access'. These embedded customers will require an MPAN so that they can have their electricity supplied by a Supplier of their choice.
- 2.76. Licence exempt distribution networks owners can provide third party access using either full settlement metering or the difference metering approach.

Full settlement metering

- 2.77. This is where a licence exempt distribution network is set up so that each embedded installation has an MPAN and Metering System and therefore all customers purchase electricity from their chosen Supplier. In this case there are no Settlement Metering Systems at the boundary between the licensed Distribution System and the exempt distribution network.
- 2.78. In this approach our UoS charges will be applied to each MPAN.

Difference metering

- 2.79. This is where one or more, but not all, customers on a licence exempt distribution network choose their own Supplier for electricity supply to their premise. Under this approach the customers requiring third party access on the exempt distribution network will have their own MPAN and must have a HH Metering System.
- 2.80. In this approach our UoS charges will be applied using net settlement.

Net Settlement

- 2.81. Where one of our MPANs (MPAN prefix 16) is embedded within a licence exempt distribution network connected to one of our distribution systems, and difference metering is in place for Settlement purposes, and we do **not** receive gross measurement data for the boundary MPAN, we will charge the boundary MPAN Supplier based on the net measurement for use of our Distribution System. Charges will also be levied directly to the Supplier of the embedded MPAN(s) connected within the licence exempt distribution network based on the actual data received.
- 2.82. The charges applicable for an embedded MPAN are unit charges only. These will be the same values as those at the voltage of connection to the licence

exempt distribution network and are shown in Annex 1. The fixed charge and capacity charge, at the agreed MIC/MEC of the boundary MPAN, will be charged to the boundary MPAN supplier.

3. Schedule of charges for use of the distribution system

- 3.1. Tables listing the charges for the distribution of electricity for UoS are published in the annexes to this document.
- 3.2. These charges are also listed in a spreadsheet which is published with this statement and can be downloaded from <http://www.enwl.co.uk/our-services/use-of-system-charges> .
- 3.3. Annex 1 contains charges applied to LV and HV Designated Properties.
- 3.4. Annex 2 contains the charges applied to our Designated EHV Properties and charges applied to LDNOs for Designated EHV Properties connected within their embedded Distribution System.
- 3.5. Annex 3 contains details of any preserved and additional charges that are valid at this time. Preserved charges are mapped to an appropriate charge and are closed to new customers.
- 3.6. Annex 4 contains the charges applied to LDNOs in respect of LV and HV Designated Properties connected in their embedded Distribution System.

4. Schedule of line loss factors

Role of line loss factors in the supply of electricity

- 4.1. Electricity entering or exiting our Distribution System is adjusted to take account of energy that is lost⁸ as it is distributed through the network. This adjustment does not affect distribution charges but is used in energy settlement to take metered consumption to a notional grid supply point so that suppliers' purchases take account for the energy lost on the Distribution System.
- 4.2. We are responsible for calculating the Line Loss Factors⁹ (LLFs) and providing these to Elexon. Elexon is the company that manage the BSC. This code covers the governance and rules for the balancing and settlement arrangements.
- 4.3. Annex 5 provides the LLFs that are used to adjust the metering system volumes to take account of losses on the distribution network.

Calculation of line loss factors

- 4.4. LLFs are calculated in accordance with BSC procedure 128 that determines the principles with which we must comply when calculating LLFs.
- 4.5. LLFs are calculated using either a generic method or a site-specific method. The generic method is used for sites connected at LV or HV and the site-specific method is used for sites connected at EHV or where a request for site-specific LLFs has been agreed. Generic LLFs will be applied to all new EHV sites until sufficient data is available for a site-specific calculation.
- 4.6. The definition of EHV used for LLF purposes differs from the definition used for defining Designated EHV Properties that is used in the EDCM. The definition used for LLF purposes can be found in our LLF methodology.
- 4.7. The Elexon website (<http://www.elexon.co.uk/reference/technical-operations/losses/>) contains more information on LLFs. This page also has links to BSC procedure 128 and to our LLF methodology.

⁸ Energy can be lost for technical and non-technical reasons and losses normally occur by heat dissipation through power flowing in conductors and transformers. Losses can also reduce if a customer's action reduces power flowing in the distribution network. This might happen when a customer generates electricity and the produced energy is consumed locally.

⁹ Also referred to as Loss Adjustment Factors.

Line loss factor time periods

- 4.8. LLFs are calculated for a set number of time periods during the year and are detailed in Annex 5.

Line loss factor tables

- 4.9. When using the LLF tables in Annex 5 reference should be made to the LLFC allocated to the MPAN to find the appropriate LLF.
- 4.10. The Elexon portal website, <https://www.elexonportal.co.uk>, contains the LLFs in standard industry data format (D0265). A user guide with details on registering and using the portal can be downloaded from:
www.elexonportal.co.uk/Userguide

5. Notes for Designated EHV Properties

EDCM LRIC nodal costs

- 5.1. A table is provided in the accompanying spreadsheet which shows the underlying LRIC nodal costs used to calculate the current EDCM charges. This spreadsheet is available to download from our website: <http://www.enwl.co.uk/our-services/use-of-system-charges>.
- 5.2. These are illustrative of the modelled costs at the time that this statement was published. A new connection will result in changes to current network utilisations, which will then form the basis of future prices: the charge determined in this statement will not necessarily be the charge in subsequent years because of the interaction between new and existing network connections and any other changes made to our Distribution System which may affect charges.

Charges for new Designated EHV Properties

- 5.3. Charges for any new Designated EHV Properties calculated after publication of the current statement will be published in an addendum to that statement as and when necessary.
- 5.4. The form of the addendum is detailed in Annex 6 to this statement.
- 5.5. The addendum will be sent to relevant DCUSA parties and published as a revised 'Schedule of Charges and Other Tables' spreadsheet on our website. The addendum will include charge information that under enduring circumstances would be found in Annex 2 and line loss factors that would normally be found in Annex 5.
- 5.6. The new Designated EHV Properties charges will be added to Annex 2 in the next full statement released.

Charges for amended Designated EHV Properties

- 5.7. Where an existing Designated EHV Property is modified and energised in the charging year, we may revise the EDCM charges for the modified Designated EHV Property. If revised charges are appropriate, an addendum will be sent to relevant DCUSA parties and published as a revised 'Schedule of Charges and Other Tables' spreadsheet on our website. The modified Designated EHV Property charges will be added to Annex 2 in the next full statement released.

Demand-side management

5.8. Electricity North West has a standard Demand Side Management (DSM) contract that is available to any Customer that is charged under the Extra High Voltage Distribution Charging Methodology (EDCM). Under this contract, Electricity North West will pay a DSM payment to any EDCM Customer who is willing to reduce their capacity by a minimum of 25% in the time periods specified by Electricity North West. The value of this payment will depend on the location of the EDCM site and how much spare capacity there is available on that part of the distribution network. Where the distribution network is very congested Electricity North West will pay more to the EDCM Customer to reduce their load. For more information please view the Electricity North West website using the following link:

<http://www.enwl.co.uk/our-services/use-of-system-charges/demand-side-management>

or contact our Charging Manager using the following email address: electricitycommercialpolicy@enwl.co.uk

6. Electricity distribution rebates

- 6.1. We have neither given nor announced any DUoS rebates to Users in the 12 months preceding the date of publication of this revision of the statement.

7. Accounting and administration services

- 7.1. We reserve the right to impose payment default remedies. The remedies are as set out in DCUSA where applicable or else as detailed in the following paragraph.
- 7.2. If any invoices that are not subject to a valid dispute remain unpaid on the due date, late payment interest (calculated at base rate plus 8%) and administration charges may be imposed.
- 7.3. Our administration charges are detailed in the following table. These charges are set at a level which is in line with the Late Payment of Commercial Debts Act;

Size of Unpaid Debt	Late Payment Fee
Up to £999.99	£40.00
£1,000 to £9,999.99	£70.00
£10,000 or more	£100.00

8. Charges for electrical plant provided ancillary to the grant of use of system

- 8.1. We do not have a schedule of the charges which may be made (i) for providing and installing any electrical plant at Entry Points or Exit Points, where such provision and installation are ancillary to the grant of Use of System, and (ii) for maintaining such plant.

Appendix 1 - Glossary

1.1. The following definitions, which can extend to grammatical variations and cognate expressions, are included to aid understanding:

Term	Definition
All-the-way Charge	A charge that is applicable to an end user rather than an LDNO. An end user in this context is a Supplier/User who has a registered MPAN or MSID and is using the Distribution System to transport energy on behalf of a Customer.
Balancing and Settlement Code (BSC)	The BSC contains the governance arrangements for electricity balancing and settlement in Great Britain. An overview document is available from www.elexon.co.uk/ELEXON Documents/trading_arrangements.pdf .
Common Distribution Charging Methodology (CDCM)	The CDCM used for calculating charges to Designated Properties as required by standard licence condition 13A of the electricity distribution licence.
Central volume allocation (CVA)	As defined in the BSC.
Customer	A person to whom a User proposes to supply, or for the time being supplies, electricity through an exit point, or from whom, a User or any relevant exempt supplier, is entitled to recover charges, compensation or an account of profits in respect of electricity supplied through an exit point; Or A person from whom a User purchases, or proposes to purchase, electricity, at an entry point (who may from time to time be supplied with electricity as a Customer of that User (or another electricity supplier) through an exit point).
Designated EHV Properties	As defined in standard condition 13B of the electricity distribution licence.
Designated Properties	As defined in standard condition 13A of the electricity distribution licence.

Term	Definition																																																												
Distributor IDs	<p>These are unique IDs that can be used, with reference to the MPAN, to identify your LDNO. The charges for other network operators can be found on their website.</p> <table border="1" data-bbox="644 405 1378 1473"> <thead> <tr> <th data-bbox="644 405 715 443">ID</th> <th data-bbox="715 405 1002 443">Name</th> <th data-bbox="1002 405 1378 443">Operator</th> </tr> </thead> <tbody> <tr> <td data-bbox="644 443 715 510">10</td> <td data-bbox="715 443 1002 510">Eastern Power Networks</td> <td data-bbox="1002 443 1378 510">UK Power Networks</td> </tr> <tr> <td data-bbox="644 510 715 548">11</td> <td data-bbox="715 510 1002 548">East Midlands</td> <td data-bbox="1002 510 1378 548">Western Power Distribution</td> </tr> <tr> <td data-bbox="644 548 715 616">12</td> <td data-bbox="715 548 1002 616">London Power Networks</td> <td data-bbox="1002 548 1378 616">UK Power Networks</td> </tr> <tr> <td data-bbox="644 616 715 683">13</td> <td data-bbox="715 616 1002 683">Merseyside and North Wales</td> <td data-bbox="1002 616 1378 683">Scottish Power</td> </tr> <tr> <td data-bbox="644 683 715 721">14</td> <td data-bbox="715 683 1002 721">Midlands</td> <td data-bbox="1002 683 1378 721">Western Power Distribution</td> </tr> <tr> <td data-bbox="644 721 715 759">15</td> <td data-bbox="715 721 1002 759">Northern</td> <td data-bbox="1002 721 1378 759">Northern Powergrid</td> </tr> <tr> <td data-bbox="644 759 715 797">16</td> <td data-bbox="715 759 1002 797">North Western</td> <td data-bbox="1002 759 1378 797">Electricity North West</td> </tr> <tr> <td data-bbox="644 797 715 864">17</td> <td data-bbox="715 797 1002 864">Scottish Hydro Electric</td> <td data-bbox="1002 797 1378 864">Scottish Hydro Electric Power Distribution plc</td> </tr> <tr> <td data-bbox="644 864 715 902">18</td> <td data-bbox="715 864 1002 902">South Scotland</td> <td data-bbox="1002 864 1378 902">Scottish Power</td> </tr> <tr> <td data-bbox="644 902 715 969">19</td> <td data-bbox="715 902 1002 969">South Eastern Power Networks</td> <td data-bbox="1002 902 1378 969">UK Power Networks</td> </tr> <tr> <td data-bbox="644 969 715 1037">20</td> <td data-bbox="715 969 1002 1037">Southern Electric</td> <td data-bbox="1002 969 1378 1037">Southern Electric Power Distribution plc</td> </tr> <tr> <td data-bbox="644 1037 715 1075">21</td> <td data-bbox="715 1037 1002 1075">South Wales</td> <td data-bbox="1002 1037 1378 1075">Western Power Distribution</td> </tr> <tr> <td data-bbox="644 1075 715 1113">22</td> <td data-bbox="715 1075 1002 1113">South Western</td> <td data-bbox="1002 1075 1378 1113">Western Power Distribution</td> </tr> <tr> <td data-bbox="644 1113 715 1151">23</td> <td data-bbox="715 1113 1002 1151">Yorkshire</td> <td data-bbox="1002 1113 1378 1151">Northern Powergrid</td> </tr> <tr> <td data-bbox="644 1151 715 1189">24</td> <td data-bbox="715 1151 1002 1189">GTC</td> <td data-bbox="1002 1151 1378 1189">Independent Power Networks</td> </tr> <tr> <td data-bbox="644 1189 715 1227">25</td> <td data-bbox="715 1189 1002 1227">ESP Electricity</td> <td data-bbox="1002 1189 1378 1227">ESP Electricity</td> </tr> <tr> <td data-bbox="644 1227 715 1265">26</td> <td data-bbox="715 1227 1002 1265">Energetics</td> <td data-bbox="1002 1227 1378 1265">Energetics Electricity Ltd</td> </tr> <tr> <td data-bbox="644 1265 715 1303">27</td> <td data-bbox="715 1265 1002 1303">GTC</td> <td data-bbox="1002 1265 1378 1303">The Electricity Network Company Ltd</td> </tr> <tr> <td data-bbox="644 1303 715 1364">29</td> <td data-bbox="715 1303 1002 1364">Harlaxton Energy Networks</td> <td data-bbox="1002 1303 1378 1364">Harlaxton Energy Networks</td> </tr> </tbody> </table>	ID	Name	Operator	10	Eastern Power Networks	UK Power Networks	11	East Midlands	Western Power Distribution	12	London Power Networks	UK Power Networks	13	Merseyside and North Wales	Scottish Power	14	Midlands	Western Power Distribution	15	Northern	Northern Powergrid	16	North Western	Electricity North West	17	Scottish Hydro Electric	Scottish Hydro Electric Power Distribution plc	18	South Scotland	Scottish Power	19	South Eastern Power Networks	UK Power Networks	20	Southern Electric	Southern Electric Power Distribution plc	21	South Wales	Western Power Distribution	22	South Western	Western Power Distribution	23	Yorkshire	Northern Powergrid	24	GTC	Independent Power Networks	25	ESP Electricity	ESP Electricity	26	Energetics	Energetics Electricity Ltd	27	GTC	The Electricity Network Company Ltd	29	Harlaxton Energy Networks	Harlaxton Energy Networks
ID	Name	Operator																																																											
10	Eastern Power Networks	UK Power Networks																																																											
11	East Midlands	Western Power Distribution																																																											
12	London Power Networks	UK Power Networks																																																											
13	Merseyside and North Wales	Scottish Power																																																											
14	Midlands	Western Power Distribution																																																											
15	Northern	Northern Powergrid																																																											
16	North Western	Electricity North West																																																											
17	Scottish Hydro Electric	Scottish Hydro Electric Power Distribution plc																																																											
18	South Scotland	Scottish Power																																																											
19	South Eastern Power Networks	UK Power Networks																																																											
20	Southern Electric	Southern Electric Power Distribution plc																																																											
21	South Wales	Western Power Distribution																																																											
22	South Western	Western Power Distribution																																																											
23	Yorkshire	Northern Powergrid																																																											
24	GTC	Independent Power Networks																																																											
25	ESP Electricity	ESP Electricity																																																											
26	Energetics	Energetics Electricity Ltd																																																											
27	GTC	The Electricity Network Company Ltd																																																											
29	Harlaxton Energy Networks	Harlaxton Energy Networks																																																											
Distribution Connection and Use of System Agreement (DCUSA)	<p>The DCUSA is a multi-party contract between the licensed electricity distributors, suppliers, generators and Offshore Transmission Owners of Great Britain.</p> <p>It is a requirement that all licensed electricity distributors and suppliers become parties to the DCUSA.</p>																																																												
Distribution Network Operator (DNO)	<p>An electricity distributor that operates one of the 14 distribution services areas and in whose electricity distribution licence the requirements of Section B of the standard conditions of that licence have effect.</p>																																																												
Distribution Services Area	<p>The area specified by the Gas and Electricity Markets Authority within which each DNO must provide specified distribution services.</p>																																																												

Term	Definition
Distribution System	<p>The system consisting (wholly or mainly) of electric lines owned or operated by an authorised distributor that is used for the distribution of electricity from:</p> <ul style="list-style-type: none"> • Grid Supply Points or generation sets or other entry points <p>to the points of delivery to:</p> <ul style="list-style-type: none"> • Customers or Users or any transmission licensee in its capacity as operator of that licensee's transmission system or the Great Britain (GB) transmission system and includes any remote transmission assets (owned by a transmission licensee within England and Wales) <p>that are operated by that authorised distributor and any electrical plant, electricity meters, and metering equipment owned or operated by it in connection with the distribution of electricity, but does not include any part of the GB transmission system.</p>
EHV Distribution Charging Methodology (EDCM)	The EDCM used for calculating charges to Designated EHV Properties as required by standard licence condition 13B of the Electricity Distribution Licence.
Electricity Distribution Licence	The Electricity Distribution Licence granted or treated as granted pursuant to section 6(1) of the Electricity Act 1989.
Electricity Distributor	Any person who is authorised by an Electricity Distribution Licence to distribute electricity.
Embedded LDNO	This refers to an LDNO operating a distribution network which is embedded within another distribution network.
Embedded Network	An electricity Distribution System operated by an LDNO and embedded within another distribution network.
Entry Point	A boundary point at which electricity is exported onto a Distribution System from a connected installation or from another Distribution System, not forming part of the total system (boundary point and total system having the meaning given to those terms in the BSC).
Exit Point	A point of connection at which a supply of electricity may flow from the Distribution System to the Customer's installation or User's installation or the Distribution System of another person.
Extra-High Voltage (EHV)	Nominal voltages of 22kV and above.
Gas and Electricity Markets Authority (GEMA)	As established by the Utilities Act 2000.
Grid Supply Point (GSP)	A metered connection between the National Grid Electricity Transmission system and the licensee's distribution system at which electricity flows to or from the Distribution System.

Term	Definition
GSP group	A distinct electrical system that is supplied from one or more GSPs for which total supply into the GSP group can be determined for each half hour.
High Voltage (HV)	Nominal voltages of at least 1kV and less than 22kV.
Invalid Settlement Combination	A Settlement combination that is not recognised as a valid combination in market domain data - see https://www.elexonportal.co.uk/MDDVIEWER .
kVA	Kilovolt amperes.
kVArh	Kilovolt ampere reactive hour.
kW	Kilowatt.
kWh	Kilowatt hour (equivalent to one "unit" of electricity).
Licensed Distribution Network Operator (LDNO)	The holder of a licence in respect of distribution activities in Great Britain.
Line Loss Factor (LLF)	The factor that is used in Settlement to adjust the metering system volumes to take account of losses on the Distribution System.
Line Loss Factor Class (LLFC)	An identifier assigned to an SVA metering system which is used to assign the LLF and use of system charges.
Load Factor	$= \frac{\text{annual consumption (kWh)}}{\text{maximum demand (kW)} \times \text{hours in year}}$
Low Voltage (LV)	Nominal voltages below 1kV.
Market Domain Data (MDD)	MDD is a central repository of reference data available to all Users involved in Settlement. It is essential to the operation of SVA trading arrangements.
Maximum Export Capacity (MEC)	The MEC of apparent power expressed in kVA that has been agreed can flow through the entry point to the Distribution System from the Customer's installation as specified in the connection agreement.
Maximum Import Capacity (MIC)	The MIC of apparent power expressed in kVA that has been agreed can flow through the exit point from the Distribution System to the Customer's installation as specified in the connection agreement.

Term	Definition
Measurement Class	<p>A classification of metering systems used in the BSC which indicates how consumption is measured, i.e.:</p> <ul style="list-style-type: none"> • Measurement class A – non-half-hourly metering equipment; • Measurement class B – non-half-hourly unmetred supplies; • Measurement class C – half-hourly metering equipment at or above 100kW premises; • Measurement class D – half-hourly unmetred supplies; and • Measurement class E – half-hourly metering equipment below 100kW premises, and from 5 November 2015, with current transformer. • Measurement class F – half hourly metering equipment at below 100kW premises with current transformer or whole current, and at domestic premises • Measurement class G – half hourly metering equipment at below 100kW premises with whole current and not at domestic premises
Meter Timeswitch Code (MTC)	<p>MTCs are three digit codes allowing suppliers to identify the metering installed in Customers' premises. They indicate whether the meter is single or multi-rate, pre-payment or credit, or whether it is 'related' to another meter. Further information can be found in MDD.</p>
Metering Point	<p>The point at which electricity that is exported to or imported from the licensee's Distribution System is measured, is deemed to be measured, or is intended to be measured and which is registered pursuant to the provisions of the MRA. For the purposes of this statement, GSPs are not 'metering points'.</p>
Metering Point Administration Number (MPAN)	<p>A number relating to a Metering Point under the MRA.</p>
Metering System	<p>Particular commissioned metering equipment installed for the purposes of measuring the quantities of exports and/or imports at the exit point or entry point.</p>
Metering System Identifier (MSID)	<p>MSID is a term used throughout the BSC and its subsidiary documents and has the same meaning as MPAN as used under the MRA.</p>
Master Registration Agreement (MRA)	<p>The MRA is an Agreement that sets out terms for the provision of Metering Point Administration Services (MPAS) Registrations, and procedures in relation to the Change of Supplier to any premise/metering point.</p>
Nested Networks	<p>This refers to a situation where there is more than one level of Embedded Network and therefore nested Distribution Systems between LDNOs (e.g. host DNO→primary nested DNO→ secondary nested DNO→customer).</p>

Term	Definition
Ofgem	Office of Gas and Electricity Markets – Ofgem is governed by GEMA and is responsible for the regulation of the distribution companies.
Profile Class (PC)	A categorisation applied to NHH MPANs and used in Settlement to group Customers with similar consumption patterns to enable the calculation of consumption profiles.
Settlement	The determination and settlement of amounts payable in respect of charges (including reconciling charges) in accordance with the BSC.
Settlement Class (SC)	The combination of Profile Class, Line Loss Factor Class, Time Pattern Regime and Standard Settlement Configuration, by Supplier within a GSP group and used for Settlement.
Standard Settlement Configuration (SSC)	A standard metering configuration relating to a specific combination of Time Pattern.
Supercustomer	The method of billing Users for use of system on an aggregated basis, grouping together consumption and standing charges for all similar NHH metered Customers or aggregated HH metered Customers.
Supercustomer DUoS Report	A report of profiled data by Settlement Class providing counts of MPANs and units consumed.
Supplier	An organisation with a supply licence responsible for electricity supplied to and/or exported from a metering point.
Supplier Volume Allocation (SVA)	As defined in the BSC.
Time Pattern Regime (TPR)	The pattern of switching behaviour through time that one or more meter registers follow.
Unmetered Supplies	Exit points deemed to be suitable as unmetered supplies as permitted in the Electricity (Unmetered Supply) Regulations 2001 and where operated in accordance with BSC procedure 520 ¹⁰ .
Use of System Charges	Charges which are applicable to those parties which use the Distribution System.
User	Someone that has a use of system agreement with the DNO e.g. a supplier, generator or other DNO.

¹⁰ Balancing and Settlement Code Procedures are available from <http://www.elexon.co.uk/pages/bscps.aspx>

Appendix 2 - Guidance notes¹¹

Background

- 1.1. The electricity bill from your Supplier contains an element of charge to cover electricity distribution costs. This distribution charge covers the cost of operating and maintaining a safe and reliable Distribution System that forms the 'wires' that transport electricity between the national transmission system and end users such as homes and businesses. Our Distribution System includes overhead lines, underground cables, as well as substations and transformers.
- 1.2. In most cases, your Supplier is invoiced for the distribution charge and this is normally part of your total bill. In some cases, for example business users, the supplier may pass through the distribution charge as an identifiable line item on the electricity bill.
- 1.3. Where electricity is generated at a property your Supplier may receive a credit for energy that is exported on to the Distribution System. These credits are intended to reflect that the exported generation may reduce the need for traditional demand led reinforcement of the Distribution System.
- 1.4. Understanding your distribution charges could help you reduce your costs and increase your credits. This is achieved by understanding the components of the charge to help you identify whether there may be opportunities to change the way you use the Distribution System.

Meter point administration

- 1.5. We are responsible for managing the electricity supply points that are connected to our Distribution System. Typically every supply point is identified by a Meter Point Administration Number (MPAN). A few supply points may have more than one MPAN depending on the metering configuration (e.g. a school which may have an MPAN for the main supply and a MPAN for catering).
- 1.6. The full MPAN is a 21 digit number, preceded by an 'S'. The MPAN applicable to a supply point is found on the electricity bill from your Supplier. This number enables you to establish who your electricity distributor is, details of the characteristics of the supply and importantly the distribution charges that are applicable to your premise.

¹¹ These guidance notes are provided for additional information and do not form part of the application of charges.

- 1.7. The 21-digit number is normally presented in two sections as shown in the following diagram. The top section is supplementary data which gives information about the characteristics of supply, while the bottom 'core' is the unique identifier.

Full MPAN diagram

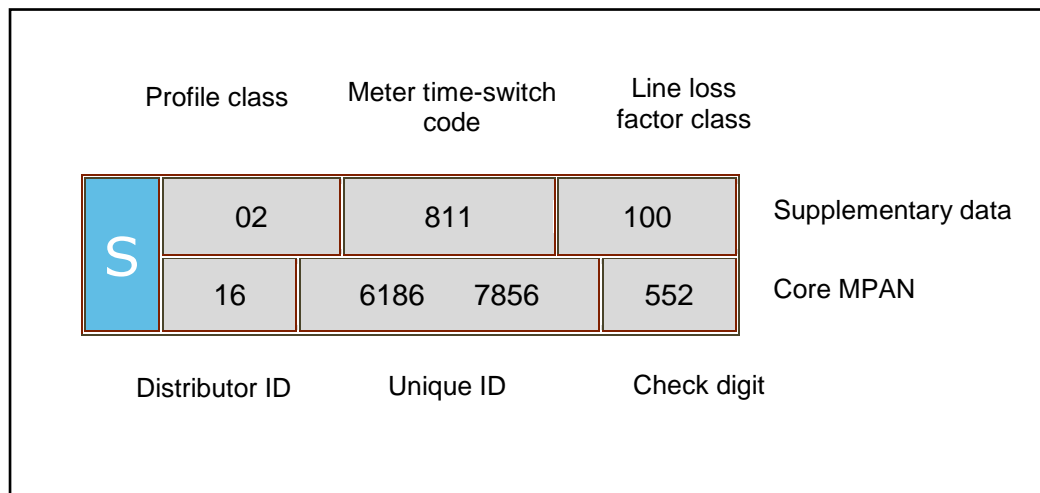

- 1.8. Generally, you will only need to know the Distributor ID and line loss factor class to identify the distribution charges for your premise. However, there are some premises where charges are specific to that site. In these instances the charges are identified by the core MPAN. The Distributor ID for Electricity North West is 16. Other Distributor IDs can be referenced in the glossary.
- 1.9. Additionally it can be useful to understand the profile class provided in the supplementary data. The profile class will be a number between 00 and 08. The following list provides details of the allocation of profile classes to types of customers:
- '01' – Domestic customers with unrestricted supply
 - '02' – Domestic customers with restricted load, for example off-peak heating
 - '03' – Non-domestic customers with unrestricted supply
 - '04' – Non-domestic customers with restricted load, for example off-peak heating
 - '05' – Non-domestic maximum demand customers with a Load Factor of less than 20%
 - '06' – Non-domestic maximum demand customers with a Load Factor between 20% and 30%

- '07' – Non-domestic maximum demand customers with a Load Factor between 30% and 40%
 - '08' – Non-domestic maximum demand customers with a Load Factor over 40% or non-half-hourly metered generation customers
 - '00' – Half-hourly metered demand and generation customers
- 1.10. Unmetered Supplies will be allocated to profile class 01, 08 and 00 depending on the type of load or the measurement method of the load.
- 1.11. The allocation of the profile class will affect your charges. If you feel that you have been allocated the wrong profile class, please contact your Supplier as they are responsible for this.

Your charges

- 1.12. All distribution charges that relate to our Distributor ID 16 are provided in this statement.
- 1.13. You can identify your charges by referencing your line loss factor class, from Annex 1. If the MPAN is for a Designated EHV Property then the charges will be found in Annex 2. In a few instances, the charges maybe contained in Annex 3. When identifying charges in Annex 2, please note that some line loss factor classes have more than one charge. In this instance you will need to select the correct charge by cross referencing with the core MPAN provided in the table.
- 1.14. Once you have identified which charge structure applies to your MPAN then you will be able to calculate an estimate of your distribution charge using the calculator provided in the spreadsheet 'Schedule of charges and other tables' found in the sheet called 'Charge Calculator'. This spreadsheet can be downloaded from <http://www.enwl.co.uk/our-services/use-of-system-charges>.

Reducing your charges

- 1.15. The most effective way to reduce your energy charges is to reduce your consumption by switching off or using more energy efficient appliances. However, there are also other potential opportunities to reduce your distribution charges; for example, it may be beneficial to shift demand or generation to a better time period where demand use is likely to be cheaper outside peak periods and generation credits more beneficial, although the ability to directly benefit will be linked to the structure of your supply charges.

- 1.16. The calculator mentioned above provides the opportunity to establish a forecast of the change in distribution charges that could be achieved if you are able to change any of the consumption related inputs.

Reactive power and reactive power charges

- 1.17. Reactive power is a separately charged component of connections that are half-hourly metered. Reactive power charges are generally avoidable if best practice design of the properties' electrical installation has been provided in order to maintain a power factor between 0.95 and unity at the Metering Point.
- 1.18. Reactive Power (kVA_{rh}) is the difference between working power (active power measured in kW) and total power consumed (apparent power measured in kVA). Essentially it is a measure of how efficiently electrical power is transported through an electrical installation or a Distribution System.
- 1.19. Power flowing with a power factor of unity results in the most efficient loading of the Distribution System. Power flowing with a power factor of less than 0.95 results in much higher losses in the Distribution System, a need to potentially provide higher capacity electrical equipment and consequently a higher bill for you the consumer. A comparatively small improvement in power factor can bring about a significant reduction in losses since losses are proportional to the square of the current.
- 1.20. Different types of electrical equipment require some 'reactive power' in addition to 'active power' in order to work effectively. Electric motors, transformers and fluorescent lighting, for example, may produce poor power factors due to the nature of their inductive load. However, if good design practice is applied then the poor power factor of appliances can be corrected as near as possible to source. Alternatively poor power factor can be corrected centrally near to the meter.
- 1.21. There are many advantages that can be achieved by correcting poor power factor. These include: reduced energy bills through lower reactive charges, lower capacity charges and reduced power consumption and reduced voltage drop in long cable runs.

Site-specific EDCM charges

- 1.22. A site classified as a Designated EHV Property is subject to a locational based charging methodology (referred to as EDCM) for higher voltage network users. Distributors use two approved approaches: Long Run Incremental Cost Pricing

(LRIC) and Forward Cost Pricing (FCP) and we use the LRIC. The EDCM will apply to Customers connected at Extra High Voltage or connected at High Voltage and metered at a high voltage substation.

- 1.23. EDCM charges are site-specific, reflecting the degree to which the local and higher voltage networks have the capacity to serve more demand or generation without the need to upgrade the electricity infrastructure. The charges also reflect the networks specifically used to deliver the electricity to the site as well as the usage at the site. Generators with non-intermittent output and deemed to be providing beneficial support to our networks may qualify to receive payment.
- 1.24. The charges under the EDCM comprise of the following individual components:
- a) **Fixed charge** - This charge recovers operational costs associated with those connection assets that are provided for the 'sole' use of the Customer. The value of these assets, is used as a basis to derive the charge.
 - b) **Capacity charge (pence/kVA/day)** -This charge, comprises the relevant LRIC component, the National Grid Electricity Transmission cost and other regulated costs.

Capacity charges are levied on the MIC, MEC and any exceeded capacity. You may wish to review your MIC or MEC periodically to ensure it remains appropriate for your needs as you may be paying for more capacity than you require. If you wish to make changes contact us via the details in paragraph 1.12.

The LRIC cost is locational and reflects our assessment of future network reinforcement necessary at voltage of connection (local) and beyond at all higher voltages (remote) relevant to the customer's connection. This results in the allocation of higher costs in more capacity congested parts of the network reflecting the greater likelihood of future reinforcement in these areas and the allocation of lower costs in less congested parts of the network. The local LRIC cost is included in the capacity charge.

Our regulated costs include direct and indirect operational costs and a residual amount to ensure recovery of our regulated allowed revenue. The capacity charge recovers these costs using the customer usage profile and the relevant

assets being used to transport electricity between the source substation and customer's Metering Point.

c) **Super-red unit charge (pence/kWh)** - This charge recovers the remote LRIC component. The charge is positive for import and negative for export which means you can either reduce your charges by minimising consumption or increasing export at those times. The charge is applied on consumption during the Super-red time period as detailed in annex 2.

1.25. Future charge rates may be affected by consumption during the Super-red period. Therefore reducing consumption in the Super-red time period may be beneficial.

1.26. **Reactive Power** -The EDCM does not include a separate charge component for any reactive power flows (kVAr) for either demand or generation. However, the EDCM charges do reflect the effect on the network of the customer's power factor for example, unit charges can increase if your site power factor is poor (lower than 0.95). Improving your site's power factor will also reduce the maximum demand (kVA) for the same power consumed in kW thus providing scope to reduce your agreed capacity requirements.

Annex 1 - Schedule of Charges for use of the Distribution System by LV and HV Designated Properties

Electricity North West - Effective from 01 April 2015 - Final LV and HV charges

Time Bands for Half Hourly Metered Properties			
Time periods	Red Time Band	Amber Time Band	Green Time Band
Monday to Friday (Including Bank Holidays) All Year	16:00 to 19:00		
Monday to Friday (Including Bank Holidays) All Year		09:00 to 16:00 19:00 to 20:30	
Monday to Friday (Including Bank Holidays) All Year			00.00 - 09.00 20.30 - 24.00
Saturday and Sunday All Year		16:00 to 19:00	00.00 - 16.00 19.00 - 24.00
Notes	All the above times are in UK Clock time		

Time Bands for Half Hourly Unmetered Properties			
	Black Time Band	Yellow Time Band	Green Time Band
Monday to Friday (Including Bank Holidays) March to October Inclusive		09.00 - 20.30	00.00 - 09.00 20.30 - 24.00
Monday to Friday (Including Bank Holidays) Nov to Feb Inclusive	16:00 to 19:00	09:00 - 16:00 19:00 - 20:30	00.00 - 09.00 20.30 - 24.00
Saturday and Sunday		16:00 to 19:00	00.00 - 16.00 19.00 - 24.00
Notes	All the above times are in UK Clock time		

	Open LLFCs	PCs	Unit rate 1 p/kWh (red/black)	Unit rate 2 p/kWh (amber/yellow)	Unit rate 3 p/kWh (green)	Fixed charge p/MPAN/day	Capacity charge p/kVA/day	Reactive power charge p/kVAh	Excess capacity charge p/kVA/day	Closed LLFCs
Domestic Unrestricted ¹	011, 041, 441, 511	1	2.311			4.72				
Domestic Two Rate ¹	031, 051, 061, 451, 531	2	2.296	0.186		4.72				
Domestic Off Peak (related MPAN)	081, 581	2	0.257							
Small Non Domestic Unrestricted	131, 191, 631	3	2.002			3.35				
Small Non Domestic Two Rate	161, 171, 661	4	2.082	0.169		3.35				
Small Non Domestic Off Peak (related MPAN)	091, 591	4	0.186							
LV Medium Non-Domestic	241, 431, 481, 751	5-8	2.104	0.157		22.76				
LV Sub Medium Non-Domestic	242, 432, 482, 752	5-8	1.764	0.127		59.89				
HV Medium Non-Domestic		5-8	1.148	0.069		208.33				
LV Network Domestic	821		13.449	1.487	0.198	3.35				
LV Network Non-Domestic Non-CT	831		11.969	1.308	0.173	3.35				
LV HH Metered	801		9.078	0.930	0.122	12.86	3.23	0.311	3.23	
LV Sub HH Metered	802		7.441	0.706	0.092	41.18	3.22	0.234	3.22	
HV HH Metered	803		5.328	0.437	0.056	91.47	3.06	0.147	3.06	
NHH UMS category A	761	8	2.975							
NHH UMS category B	771	1	3.334							
NHH UMS category C	781	1	4.811							
NHH UMS category D	791	1	2.809							
LV UMS (Pseudo HH Metered)	811		32.164	2.738	1.725					
LV Generation NHH or Aggregate HH	961	8&0	-1.027							
LV Sub Generation NHH	962	8	-0.825							
LV Generation Intermittent	971		-1.027					0.240		
LV Generation Non-Intermittent	981		-7.595	-0.929	-0.126			0.240		
LV Sub Generation Intermittent	972		-0.825					0.195		
LV Sub Generation Non-Intermittent	982		-6.180	-0.728	-0.099			0.195		
HV Generation Intermittent	973		-0.574			6.51		0.138		
HV Generation Non-Intermittent	983		-4.446	-0.472	-0.064	6.51		0.138		
NOTES	¹ The fixed rate for the domestic tariffs has been increased by 1.37p/MPAN/day to recover the £5 discount that was provided to domestic customers in 2014/15. This change has been made outside of the charging methodology and consent to not comply with the charging methodology has been provided by the Authority. The published CDCM model contains the prices for domestic customers before the discount has been applied.									

Annex 2 - Schedule of Charges for use of the Distribution System by Designated EHV Properties (including LDNOs with Designated EHV Properties/end-users).

Electricity North West - Effective from 01 April 2015 - Final EDCM charges

Time Periods for Designated EHV Properties

Time periods	Super Red Time Band
Monday to Friday (Including Bank Holidays) November to February Inclusive	16:00 - 19:00
Notes	All the above times are in UK Clock time

Import Unique Identifier	LLFC	Import MPANs/MSIDs	Export Unique Identifier	LLFC	Export MPANs/MSIDs	Name	Import Super Red unit rate (p/kWh)	Import fixed charge (p/day)	Import capacity rate (p/kVA/day)	Import exceeded capacity rate (p/kVA/day)	Export Super Red unit rate (p/kWh)	Export fixed charge (p/day)	Export capacity rate (p/kVA/day)	Export exceeded capacity rate (p/kVA/day)
Tariff 1	610	160000132063		-		Site 1	0.000	13689.82	2.47	2.47				
Tariff 2	500	1620000772484		-		Site 2	0.000	1187.93	4.68	4.68				
Tariff 3	650	160000139069		-		Site 3	0.163	791.96	3.53	3.53				
Tariff 4	660	160000138836		-		Site 4	0.058	2523.99	2.27	2.27				
Tariff 5	640	160000138766		-		Site 5	1.005	2116.19	5.83	5.83				
Tariff 6	700	160000138845		-		Site 6	0.260	3559.05	1.77	1.77				
Tariff 7	900	1620000595805		-		Site 7	1.101	791.96	5.25	5.25				
Tariff 8	670	160000176743 160000176734		-		Site 8	0.000	1832.75	10.81	10.81				
Tariff 9	320	1630000239738 1630000239747		-		Site 9	0.000	19508.90	1.98	1.98				
Tariff 10	850	1620000847420		-		Site 10	0.346	791.96	6.21	6.21				
Tariff 11	450	1620001195216		-		Site 11	3.807	7759.39	5.25	5.25				
Tariff 12	460	1620001102921 1620001102912	Tariff 89	470	1620001102930 1620001102940	Site 12	0.000	645.93	1.06	1.06				
Tariff 13	680	160000135019	Tariff 90	690	1620000193245	Site 13	0.152	216.23	2.75	2.75	-0.988	398.64	0.07	0.07
Tariff 14	520	1620000398404	Tariff 91	730	1630000403060	Site 14	0.186	1635.25	2.57	2.57				
Tariff 15	510	1620000398399 1620000145890	Tariff 92	720	1630000408166 1630000408148	Site 15	0.000	3012.30	2.96	2.96				
Tariff 16	530	1620000398440 1620000398461	Tariff 93	770	1630000402252 1630000402261	Site 16	0.000	7062.46	3.87	3.87				
Tariff 17	540	1620000398413 1620000273477	Tariff 94	740	1630000402304 1630000402299	Site 17	0.913	3052.46	2.20	2.20				
Tariff 18	550	1620000398422 1620000145915	Tariff 95	750	1630000403070	Site 18	0.058	3357.71	4.72	4.72				
Tariff 19	810	1620000622316	Tariff 96	820	1620000622325	Site 19	0.215	1526.23	4.93	4.93				
Tariff 20	830	1620000828143	Tariff 97	840	1620000828134	Site 20	0.000	15.73	2.53	2.53	-1.054	2146.51	0.07	0.07

Note: The list of MPANs / MSIDs provided may be incomplete; the DNO reserves the right to apply the listed charges to any other MPANs / MSIDs associated with the site.

Import Unique Identifier	LLFC	Import MPANs/MSIDs	Export Unique Identifier	LLFC	Export MPANs/MSIDs	Name	Import Super Red unit rate (p/kWh)	Import fixed charge (p/day)	Import capacity rate (p/kVA/day)	Import exceeded capacity rate (p/kVA/day)	Export Super Red unit rate (p/kWh)	Export fixed charge (p/day)	Export capacity rate (p/kVA/day)	Export exceeded capacity rate (p/kVA/day)
Tariff 21	960	1620000388390	Tariff 98	970	1620000388406	Site 21	0.000	309.04	1.38	1.38				
Tariff 22	370	1630000165174	Tariff 99	360	1630000165183	Site 22	0.140	2.17	3.71	3.71				
Tariff 23	410	1620001681340	Tariff 100	420	1620001681359	Site 23	2.547	2.95	4.51	4.51	-6.868	864.61	0.07	0.07
Tariff 24	430	1620001638558	Tariff 101	440	1620001638567	Site 24	0.295	1.84	2.03	2.03				
Tariff 25	340	1630000215620	Tariff 102	350	1630000215630	Site 25	0.395	10.16	3.78	3.78				
Tariff 26	480	1620000703611	Tariff 103	490	1620000703620	Site 26	1.977	2.01	4.03	4.03				
Tariff 27	600	1620000297228	Tariff 104	590	1620000297237	Site 27	0.171	18.45	1.72	1.72				
Tariff 28	980	1620000390840	Tariff 105	990	1620000390850	Site 28	0.035	1.75	2.41	2.41				
Tariff 29	280	1630000474610	Tariff 106	290	1630000474683	Site 29	0.000	40.21	1.54	1.54	0.000	10454.32	0.07	0.07
Tariff 30	260	1630000799836	Tariff 107	270	1630000799845	Site 30	0.310	8.37	2.02	2.02	0.000	830.33	0.07	0.07
Tariff 31	180	1640000177307	Tariff 108	190	1640000177316	Site 31	0.829	108.07	2.89	2.89	0.000	6616.41	0.07	0.07
Tariff 32	200	1640000063195	Tariff 109	210	1640000063200	Site 32	0.000	3688.21	0.96	0.96	0.000	4760.42	0.07	0.07
Tariff 33	140	1640000082620	Tariff 110	150	1640000082630	Site 33	0.310	4.09	4.79	4.79	0.000	613.25	0.07	0.07
Tariff 34	160	1640000082286	Tariff 111	170	1640000082295	Site 34	0.694	8.92	4.42	4.42	0.000	820.93	0.07	0.07
Tariff 35	950	1620000279707		-		Site 35	2.042	22624.39	3.80	3.80				
Tariff 36	910	1600000169151		-		Site 36	0.023	145.74	7.09	7.09				
Tariff 37	920	1600000168859		-		Site 37	0.000	145.74	6.62	6.62				
Tariff 38	570	1600000136918		-		Site 38	0.000	0.00	1.35	1.35				
Tariff 39	109	1630000187381 1630000015594 1630000015619 1630000015637 1630000015567 1630000015585 1630000015600 1630000015628 1630000187372		-		Site 39	4.798	1457.42	6.52	6.52				
Tariff 40	119	1630000031105 1630000031114 1640000183347		-		Site 40	5.164	291.48	6.53	6.53				
Tariff 41	129	1600000148392		-		Site 41	0.395	145.74	3.35	3.35				
Tariff 42	139	1600000136244 1620001287727		-		Site 42	1.460	291.48	5.83	5.83				

Note: The list of MPANs / MSIDs provided may be incomplete; the DNO reserves the right to apply the listed charges to any other MPANs / MSIDs associated with the site.

Import Unique Identifier	LLFC	Import MPANs/MSIDs	Export Unique Identifier	LLFC	Export MPANs/MSIDs	Name	Import Super Red unit rate (p/kWh)	Import fixed charge (p/day)	Import capacity rate (p/kVA/day)	Import exceeded capacity rate (p/kVA/day)	Export Super Red unit rate (p/kWh)	Export fixed charge (p/day)	Export capacity rate (p/kVA/day)	Export exceeded capacity rate (p/kVA/day)
Tariff 43	149	1620001236332 1620001231510		-		Site 43	1.692	2771.85	5.22	5.22				
Tariff 44	419	1600000138108		-		Site 44	3.081	291.48	6.24	6.24				
Tariff 45	169	1600000132620 1600000132630		-		Site 45	3.538	874.45	5.64	5.64				
Tariff 46	179	1620000531564 1620000531582		-		Site 46	5.376	437.23	5.90	5.90				
Tariff 47	189	1600000137841 1600000137850		-		Site 47	4.540	6653.15	3.56	3.56				
Tariff 48	199	1600000134831 1600000134840		-		Site 48	1.039	8408.14	5.01	5.01				
Tariff 49	209	1600000134901 1600000134910		-		Site 49	1.615	728.71	8.44	8.44				
Tariff 50	219	1600000155460		-		Site 50	0.167	1397.34	3.54	3.54				
Tariff 51	229	1600000132392		-		Site 51	1.295	291.48	2.93	2.93				
Tariff 52	239	1600000134850		-		Site 52	1.279	291.48	6.98	6.98				
Tariff 53	249	1600000137318		-		Site 53	0.481	291.48	5.01	5.01				
Tariff 54	259	1600000137674		-		Site 54	5.962	145.74	7.73	7.73				
Tariff 55	369	1600000137823		-		Site 55	4.199	291.48	7.66	7.66				
Tariff 56	289	1600000138516		-		Site 56	2.212	145.74	5.86	5.86				
Tariff 57	299	1600000134822		-		Site 57	1.067	8395.62	5.34	5.34				
Tariff 58	309	1600000134984		-		Site 58	1.441	4162.18	4.12	4.12				
Tariff 59	319	1600000133856		-		Site 59	3.433	145.74	3.85	3.85				
Tariff 60	329	1600000138924		-		Site 60	1.550	291.48	7.68	7.68				
Tariff 61	339	1600000135064		-		Site 61	2.439	291.48	6.04	6.04				
Tariff 62	349	1600000132036	Tariff 112	-	1640000285020	Site 62	4.251	7640.51	5.67	5.67				
Tariff 63	359	1600000132045		-		Site 63	0.408	3590.56	3.80	3.80				
Tariff 64	269	1600000138311		-		Site 64	0.916	4986.62	5.55	5.55				
Tariff 65	529	1600000177747 1600000177756		-		Site 65	2.062	291.48	4.97	4.97				
Tariff 66	389	1600000139087	Tariff 113	499	1620000174048	Site 66	1.779	80.12	6.15	6.15				
Tariff 67	439	1620000418238	Tariff 114	479	1620000366875	Site 67	4.806	0.64	1.92	1.92				
Tariff 68	159	1620000370375 1620000401378	Tariff 115	489	1620000370366	Site 68	2.023	105.66	5.57	5.57				

Note: The list of MPANs / MSIDs provided may be incomplete; the DNO reserves the right to apply the listed charges to any other MPANs / MSIDs associated with the site.

Import Unique Identifier	LLFC	Import MPANs/MSIDs	Export Unique Identifier	LLFC	Export MPANs/MSIDs	Name	Import Super Red unit rate (p/kWh)	Import fixed charge (p/day)	Import capacity rate (p/kVA/day)	Import exceeded capacity rate (p/kVA/day)	Export Super Red unit rate (p/kWh)	Export fixed charge (p/day)	Export capacity rate (p/kVA/day)	Export exceeded capacity rate (p/kVA/day)
Tariff 69	110	1640000199737	Tariff 116	120	1640000199746	Site 69	2.636	13.42	4.97	4.97	0.000	1144.05	0.07	0.07
Tariff 70	220	1640000264119	Tariff 117	230	1640000264128	Site 70	0.248	17.51	5.42	5.42	0.000	467.01	0.07	0.07
Tariff 71	80	1640000264146	Tariff 118	090	1640000264155	Site 71	0.434	39.90	3.99	3.99	0.000	754.53	0.07	0.07
Tariff 72	40	1640000295385	Tariff 119	050	1640000295394	Site 72	0.589	18.82	4.17	4.17	0.000	1439.70	0.07	0.07
Tariff 73	60	1640000319177	Tariff 120	070	1640000319159	Site 73	0.632	6.17	2.61	2.61	0.000	389.81	0.07	0.07
Tariff 74	68	1640000319186	Tariff 121	078	1640000319168	Site 74	0.632	6.17	3.65	3.65	0.000	389.81	0.07	0.07
Tariff 75	20	1640000408836	Tariff 122	030	1640000408845	Site 75	0.000	95.42	1.86	1.86	0.000	11545.79	0.07	0.07
Tariff 76	10	tbc	Tariff 123	100	tbc	Site 76	0.721	22.97	3.12	3.12	0.000	5685.72	0.07	0.07
Tariff 77	MSID 7016	MSID 7016	Tariff 124	MSID 7016	MSID 7016	Site 77	0.000	0.00	1.35	1.35				
Tariff 78	MSID 7039, 7040	MSID 7039, 7040	Tariff 125	MSID 7039, 7040	MSID 7039, 7040	Site 78	0.000	1241.76	3.55	3.55				
Tariff 79	MSID 7107	MSID 7107	Tariff 126	MSID 7107	MSID 7107	Site 79	0.000	1193.99	1.36	1.36				
Tariff 80	MSID 7252	MSID 7247	Tariff 127	MSID 7252	MSID 7247	Site 80	0.000	28.62	1.01	1.01	0.000	2146.51	0.07	0.07
Tariff 81	MSID 7249	MSID 7240	Tariff 128	MSID 7240	MSID 7240	Site 81	0.000	23.51	1.06	1.06	0.000	2151.62	0.07	0.07
Tariff 82	MSID 7241, 7242	MSID 7241, 7242	Tariff 129	MSID 7241, 7242	MSID 7241, 7242	Site 82	0.019	35.69	1.48	1.48	0.000	0.00	0.00	0.00
Tariff 83	MSID 7244	MSID 7244	Tariff 130	MSID 7244	MSID 7244	Site 83	0.000	11.96	1.09	1.09				
Tariff 84	MSID 2037, 2038	MSID 2037, 2038		-	-	Site 84	3.553	0.00	4.76	4.76				
Tariff 85	MSID 7156	MSID 7156		-	-	Site 85	0.310	0.00	1.78	1.78				
Tariff 86	MSID 0437	MSID 0437		-	-	Site 86	0.024	0.00	6.97	6.97				
Tariff 87	n/a	IDNO1		-		Site 87	1.549	639.91	3.23	3.23				
Tariff 88	n/a	IDNO2		-		Site 88	1.549	1499.80	2.37	2.37				

Note: The list of MPANs / MSIDs provided may be incomplete; the DNO reserves the right to apply the listed charges to any other MPANs / MSIDs associated with the site.

Annex 3 - Schedule of Charges for use of the Distribution System to Preserved/Additional LLFC Classes

Electricity North West - Effective from 01 April 2015 - Final LV and HV tariffs									
NHH preserved charges/additional LLFCs									
	Closed LLFCs	PCs	Unit rate 1 p/kWh	Unit rate 2 p/kWh	Unit rate 3 p/kWh	Fixed charge p/MPAN/day			
HV Medium Non-Domestic	483, 753	5-8	1.148	0.069		208.33			
Notes:	Unit time periods are as specified in the SSC. HV Medium Non-Domestic - This tariff will be closed to new customers and all new HV connections will be required to be half-hourly metered. Customers on HV Medium Non Domestic will be moved to the HV HH Metered tariff (LLF 803) once a Half Hourly meter has been installed.								

HH preserved charges/additional LLFCs									
	Closed LLFCs	PCs	Unit rate 1 p/kWh (red/black)	Unit rate 2 p/kWh (amber/yellow)	Unit rate 3 p/kWh (green)	Fixed charge p/MPAN/day	Capacity charge p/kVA/day	Reactive power charge p/kVArh	Excess Capacity charge p/kVA
		0							
Notes:	Time periods The time periods for the Timebands are shown in Annex 1. All times are UK clock-time.								

Annex 4 - Charges applied to LDNOs with HV/LV end users

Electricity North West - Effective from 01 April 2015 - Final LDNO tariffs

Time Bands for Half Hourly Metered Properties			
Time periods	Red Time Band	Amber Time Band	Green Time Band
Monday to Friday (Including Bank Holidays) All Year	16:00 to 19:00		
Monday to Friday (Including Bank Holidays) All Year		09:00 to 16:00 19:00 to 20:30	
Monday to Friday (Including Bank Holidays) All Year			00:00 - 09:00 20:30 - 24:00
Saturday and Sunday All Year		16:00 to 19:00	00:00 - 16:00 19:00 - 24:00
Notes	All the above times are in UK Clock time		

Time Bands for Half Hourly Unmetered Properties			
	Black Time Band	Yellow Time Band	Green Time Band
Monday to Friday (Including Bank Holidays) March to October Inclusive		09:00 - 20:30	00:00 - 09:00 20:30 - 24:00
Monday to Friday (Including Bank Holidays) Nov to Feb Inclusive	16:00 to 19:00	09:00 - 16:00 19:00 - 20:30	00:00 - 09:00 20:30 - 24:00
Saturday and Sunday		16:00 to 19:00	00:00 - 16:00 19:00 - 24:00
Notes	All the above times are in UK Clock time		

	Unique billing identifier	PCs	Unit rate 1 p/kWh (red/black)	Unit rate 2 p/kWh (amber/yellow)	Unit rate 3 p/kWh (green)	Fixed charge p/MPAN/day	Capacity charge p/kVA/day	Reactive power charge p/kVAh	Excess capacity charge p/kVA
LDNO LV: Domestic Unrestricted		1	1.536			2.23			
LDNO LV: Domestic Two Rate		2	1.526	0.124		2.23			
LDNO LV: Domestic Off Peak (related MPAN)		2	0.171						
LDNO LV: Small Non Domestic Unrestricted		3	1.331			2.23			
LDNO LV: Small Non Domestic Two Rate		4	1.384	0.112		2.23			
LDNO LV: Small Non Domestic Off Peak (related MPAN)		4	0.124						
LDNO LV: LV Medium Non-Domestic		5-8	1.399	0.104		15.13			
LDNO LV: LV Network Domestic			8.941	0.989	0.132	2.23			
LDNO LV: LV Network Non-Domestic Non-CT			7.957	0.870	0.115	2.23			
LDNO LV: LV HH Metered			6.035	0.618	0.081	8.55	2.15	0.207	2.15
LDNO LV: NHH UMS category A		8	1.978						
LDNO LV: NHH UMS category B		1	2.216						
LDNO LV: NHH UMS category C		1	3.198						
LDNO LV: NHH UMS category D		1	1.867						
LDNO LV: LV UMS (Pseudo HH Metered)			21.383	1.820	1.147				
LDNO LV: LV Generation NHH or Aggregate HH		8&0	-1.027						
LDNO LV: LV Generation Intermittent			-1.027					0.240	
LDNO LV: LV Generation Non-Intermittent			-7.595	-0.929	-0.126			0.240	
LDNO HV: Domestic Unrestricted		1	1.008			1.46			
LDNO HV: Domestic Two Rate		2	1.001	0.081		1.46			
LDNO HV: Domestic Off Peak (related MPAN)		2	0.112						
LDNO HV: Small Non Domestic Unrestricted		3	0.873			1.46			
LDNO HV: Small Non Domestic Two Rate		4	0.908	0.074		1.46			
LDNO HV: Small Non Domestic Off Peak (related MPAN)		4	0.081						
LDNO HV: LV Medium Non-Domestic		5-8	0.918	0.068		9.93			
LDNO HV: LV Network Domestic			5.865	0.648	0.086	1.46			
LDNO HV: LV Network Non-Domestic Non-CT			5.219	0.570	0.075	1.46			
LDNO HV: LV HH Metered			3.959	0.406	0.053	5.61	1.41	0.136	1.41
LDNO HV: LV Sub HH Metered			5.032	0.477	0.062	27.85	2.18	0.158	2.18
LDNO HV: HV HH Metered			4.244	0.348	0.045	72.86	2.44	0.117	2.44
LDNO HV: NHH UMS category A		8	1.297						
LDNO HV: NHH UMS category B		1	1.454						
LDNO HV: NHH UMS category C		1	2.098						
LDNO HV: NHH UMS category D		1	1.225						
LDNO HV: LV UMS (Pseudo HH Metered)			14.026	1.194	0.752				
LDNO HV: LV Generation NHH or Aggregate HH		8&0	-1.027						
LDNO HV: LV Sub Generation NHH		8	-0.825						
LDNO HV: LV Generation Intermittent			-1.027					0.240	
LDNO HV: LV Generation Non-Intermittent			-7.595	-0.929	-0.126			0.240	

Electricity North West - Effective from 01 April 2015 - Final LDNO tariffs

Time Bands for Half Hourly Metered Properties			
Time periods	Red Time Band	Amber Time Band	Green Time Band
Monday to Friday (Including Bank Holidays) All Year	16:00 to 19:00		
Monday to Friday (Including Bank Holidays) All Year		09:00 to 16:00 19:00 to 20:30	
Monday to Friday (Including Bank Holidays) All Year			00:00 - 09:00 20:30 - 24:00
Saturday and Sunday All Year		16:00 to 19:00	00:00 - 16:00 19:00 - 24:00
Notes	All the above times are in UK Clock time		

Time Bands for Half Hourly Unmetered Properties			
	Black Time Band	Yellow Time Band	Green Time Band
Monday to Friday (Including Bank Holidays) March to October Inclusive		09:00 - 20:30	00:00 - 09:00 20:30 - 24:00
Monday to Friday (Including Bank Holidays) Nov to Feb Inclusive	16:00 to 19:00	09:00 - 16:00 19:00 - 20:30	00:00 - 09:00 20:30 - 24:00
Saturday and Sunday		16:00 to 19:00	00:00 - 16:00 19:00 - 24:00
Notes	All the above times are in UK Clock time		

	Unique billing identifier	PCs	Unit rate 1 p/kWh (red/black)	Unit rate 2 p/kWh (amber/yellow)	Unit rate 3 p/kWh (green)	Fixed charge p/MPAN/day	Capacity charge p/kVA/day	Reactive power charge p/kVAh	Excess capacity charge p/kVA
LDNO HV: LV Sub Generation Intermittent			-0.825					0.195	
LDNO HV: LV Sub Generation Non-Intermittent			-6.180	-0.728	-0.099			0.195	
LDNO HV: HV Generation Intermittent			-0.574					0.138	
LDNO HV: HV Generation Non-Intermittent			-4.446	-0.472	-0.064			0.138	
LDNO HVplus: Domestic Unrestricted		1	0.863			1.25			
LDNO HVplus: Domestic Two Rate		2	0.857	0.069		1.25			
LDNO HVplus: Domestic Off Peak (related MPAN)		2	0.096						
LDNO HVplus: Small Non Domestic Unrestricted		3	0.748			1.25			
LDNO HVplus: Small Non Domestic Two Rate		4	0.778	0.063		1.25			
LDNO HVplus: Small Non Domestic Off Peak (related MPAN)		4	0.069						
LDNO HVplus: LV Medium Non-Domestic		5-8	0.786	0.059		8.50			
LDNO HVplus: LV Sub Medium Non-Domestic		5-8	1.006	0.072		34.14			
LDNO HVplus: HV Medium Non-Domestic		5-8	0.765	0.046		138.76			
LDNO HVplus: LV Network Domestic		-	5.023	0.555	0.074	1.25			
LDNO HVplus: LV Network Non-Domestic Non-CT		-	4.470	0.488	0.065	1.25			
LDNO HVplus: LV HH Metered		0	3.390	0.347	0.046	4.80	1.21	0.116	1.21
LDNO HVplus: LV Sub HH Metered		0	4.242	0.402	0.052	23.48	1.84	0.133	1.84
LDNO HVplus: HV HH Metered		0	3.549	0.291	0.037	60.92	2.04	0.098	2.04
LDNO HVplus: NHH UMS category A		8	1.111						
LDNO HVplus: NHH UMS category B		1	1.245						
LDNO HVplus: NHH UMS category C		1	1.797						
LDNO HVplus: NHH UMS category D		1	1.049						
LDNO HVplus: LV UMS (Pseudo HH Metered)		0	12.012	1.023	0.644				
LDNO HVplus: LV Generation NHH or Aggregate HH		8	-0.585			0.00			
LDNO HVplus: LV Sub Generation NHH		8	-0.549			0.00			
LDNO HVplus: LV Generation Intermittent		0	-0.585			0.00		0.137	
LDNO HVplus: LV Generation Non-Intermittent		0	-4.330	-0.530	-0.072	0.00		0.137	
LDNO HVplus: LV Sub Generation Intermittent		0	-0.549			0.00		0.130	
LDNO HVplus: LV Sub Generation Non-Intermittent		0	-4.116	-0.485	-0.066	0.00		0.130	
LDNO HVplus: HV Generation Intermittent		0	-0.574			6.51		0.138	
LDNO HVplus: HV Generation Non-Intermittent		0	-4.446	-0.472	-0.064	6.51		0.138	
LDNO EHV: Domestic Unrestricted		1	0.685			0.99			
LDNO EHV: Domestic Two Rate		2	0.680	0.055		0.99			
LDNO EHV: Domestic Off Peak (related MPAN)		2	0.076						

Electricity North West - Effective from 01 April 2015 - Final LDNO tariffs

Time Bands for Half Hourly Metered Properties			
Time periods	Red Time Band	Amber Time Band	Green Time Band
Monday to Friday (Including Bank Holidays) All Year	16:00 to 19:00		
Monday to Friday (Including Bank Holidays) All Year		09:00 to 16:00 19:00 to 20:30	
Monday to Friday (Including Bank Holidays) All Year			00.00 - 09.00 20.30 - 24.00
Saturday and Sunday All Year		16:00 to 19:00	00.00 - 16.00 19.00 - 24.00
Notes	All the above times are in UK Clock time		

Time Bands for Half Hourly Unmetered Properties			
	Black Time Band	Yellow Time Band	Green Time Band
Monday to Friday (Including Bank Holidays) March to October Inclusive		09.00 - 20.30	00.00 - 09.00 20.30 - 24.00
Monday to Friday (Including Bank Holidays) Nov to Feb Inclusive	16:00 to 19:00	09:00 - 16:00 19:00 - 20:30	00.00 - 09.00 20.30 - 24.00
Saturday and Sunday		16:00 to 19:00	00.00 - 16.00 19.00 - 24.00
Notes	All the above times are in UK Clock time		

	Unique billing identifier	PCs	Unit rate 1 p/kWh (red/black)	Unit rate 2 p/kWh (amber/yellow)	Unit rate 3 p/kWh (green)	Fixed charge p/MPAN/day	Capacity charge p/kVA/day	Reactive power charge p/kVAh	Excess capacity charge p/kVA
LDNO EHV: Small Non Domestic Unrestricted		3	0.593			0.99			
LDNO EHV: Small Non Domestic Two Rate		4	0.617	0.050		0.99			
LDNO EHV: Small Non Domestic Off Peak (related MPAN)		4	0.055						
LDNO EHV: LV Medium Non-Domestic		5-8	0.624	0.047		6.74			
LDNO EHV: LV Sub Medium Non-Domestic		5-8	0.798	0.057		27.09			
LDNO EHV: HV Medium Non-Domestic		5-8	0.607	0.036		110.11			
LDNO EHV: LV Network Domestic		-	3.985	0.441	0.059	0.99			
LDNO EHV: LV Network Non-Domestic Non-CT		-	3.547	0.388	0.051	0.99			
LDNO EHV: LV HH Metered		0	2.690	0.276	0.036	3.81	0.96	0.092	0.96
LDNO EHV: LV Sub HH Metered		0	3.366	0.319	0.042	18.63	1.46	0.106	1.46
LDNO EHV: HV HH Metered		0	2.816	0.231	0.030	48.34	1.62	0.078	1.62
LDNO EHV: NHH UMS category A		8	0.882						
LDNO EHV: NHH UMS category B		1	0.988						
LDNO EHV: NHH UMS category C		1	1.426						
LDNO EHV: NHH UMS category D		1	0.832						
LDNO EHV: LV UMS (Pseudo HH Metered)		0	9.532	0.811	0.511				
LDNO EHV: LV Generation NHH or Aggregate HH		8	-0.465			0.00			
LDNO EHV: LV Sub Generation NHH		8	-0.436			0.00			
LDNO EHV: LV Generation Intermittent		0	-0.465			0.00		0.109	
LDNO EHV: LV Generation Non-Intermittent		0	-3.436	-0.420	-0.057	0.00		0.109	
LDNO EHV: LV Sub Generation Intermittent		0	-0.436			0.00		0.103	
LDNO EHV: LV Sub Generation Non-Intermittent		0	-3.266	-0.385	-0.052	0.00		0.103	
LDNO EHV: HV Generation Intermittent		0	-0.455			5.17		0.110	
LDNO EHV: HV Generation Non-Intermittent		0	-3.528	-0.375	-0.051	5.17		0.110	
LDNO 132kV/EHV: Domestic Unrestricted		1	0.572			0.83			
LDNO 132kV/EHV: Domestic Two Rate		2	0.568	0.046		0.83			
LDNO 132kV/EHV: Domestic Off Peak (related MPAN)		2	0.064						
LDNO 132kV/EHV: Small Non Domestic Unrestricted		3	0.495			0.83			
LDNO 132kV/EHV: Small Non Domestic Two Rate		4	0.515	0.042		0.83			
LDNO 132kV/EHV: Small Non Domestic Off Peak (related MPAN)		4	0.046						
LDNO 132kV/EHV: LV Medium Non-Domestic		5-8	0.521	0.039		5.63			
LDNO 132kV/EHV: LV Sub Medium Non-Domestic		5-8	0.666	0.048		22.62			
LDNO 132kV/EHV: HV Medium Non-Domestic		5-8	0.507	0.030		91.93			
LDNO 132kV/EHV: LV Network Domestic		-	3.328	0.368	0.049	0.83			
LDNO 132kV/EHV: LV Network Non-Domestic Non-CT		-	2.962	0.324	0.043	0.83			
LDNO 132kV/EHV: LV HH Metered		0	2.246	0.230	0.030	3.18	0.80	0.077	0.80

Electricity North West - Effective from 01 April 2015 - Final LDNO tariffs

Time Bands for Half Hourly Metered Properties			
Time periods	Red Time Band	Amber Time Band	Green Time Band
Monday to Friday (Including Bank Holidays) All Year	16:00 to 19:00		
Monday to Friday (Including Bank Holidays) All Year		09:00 to 16:00 19:00 to 20:30	
Monday to Friday (Including Bank Holidays) All Year			00:00 - 09:00 20:30 - 24:00
Saturday and Sunday All Year		16:00 to 19:00	00:00 - 16:00 19:00 - 24:00
Notes	All the above times are in UK Clock time		

Time Bands for Half Hourly Unmetered Properties			
	Black Time Band	Yellow Time Band	Green Time Band
Monday to Friday (Including Bank Holidays) March to October Inclusive		09:00 - 20:30	00:00 - 09:00 20:30 - 24:00
Monday to Friday (Including Bank Holidays) Nov to Feb Inclusive	16:00 to 19:00	09:00 - 16:00 19:00 - 20:30	00:00 - 09:00 20:30 - 24:00
Saturday and Sunday		16:00 to 19:00	00:00 - 16:00 19:00 - 24:00
Notes	All the above times are in UK Clock time		

	Unique billing identifier	PCs	Unit rate 1 p/kWh (red/black)	Unit rate 2 p/kWh (amber/yellow)	Unit rate 3 p/kWh (green)	Fixed charge p/MPAN/day	Capacity charge p/kVA/day	Reactive power charge p/kVAh	Excess capacity charge p/kVA
LDNO 132kV/EHV: LV Sub HH Metered		0	2.811	0.267	0.035	15.55	1.22	0.088	1.22
LDNO 132kV/EHV: HV HH Metered		0	2.351	0.193	0.025	40.36	1.35	0.065	1.35
LDNO 132kV/EHV: NHH UMS category A		8	0.736						
LDNO 132kV/EHV: NHH UMS category B		1	0.825						
LDNO 132kV/EHV: NHH UMS category C		1	1.190						
LDNO 132kV/EHV: NHH UMS category D		1	0.695						
LDNO 132kV/EHV: LV UMS (Pseudo HH Metered)		0	7.958	0.677	0.427				
LDNO 132kV/EHV: LV Generation NHH or Aggregate HH		8	-0.388			0.00			
LDNO 132kV/EHV: LV Sub Generation NHH		8	-0.364			0.00			
LDNO 132kV/EHV: LV Generation Intermittent		0	-0.388			0.00		0.091	
LDNO 132kV/EHV: LV Generation Non-Intermittent		0	-2.869	-0.351	-0.048	0.00		0.091	
LDNO 132kV/EHV: LV Sub Generation Intermittent		0	-0.364			0.00		0.086	
LDNO 132kV/EHV: LV Sub Generation Non-Intermittent		0	-2.727	-0.321	-0.044	0.00		0.086	
LDNO 132kV/EHV: HV Generation Intermittent		0	-0.380			4.31		0.091	
LDNO 132kV/EHV: HV Generation Non-Intermittent		0	-2.946	-0.313	-0.042	4.31		0.091	
LDNO 132kV: Domestic Unrestricted		1	0.434			0.63			
LDNO 132kV: Domestic Two Rate		2	0.432	0.035		0.63			
LDNO 132kV: Domestic Off Peak (related MPAN)		2	0.048						
LDNO 132kV: Small Non Domestic Unrestricted		3	0.376			0.63			
LDNO 132kV: Small Non Domestic Two Rate		4	0.391	0.032		0.63			
LDNO 132kV: Small Non Domestic Off Peak (related MPAN)		4	0.035						
LDNO 132kV: LV Medium Non-Domestic		5-8	0.395	0.030		4.28			
LDNO 132kV: LV Sub Medium Non-Domestic		5-8	0.506	0.036		17.18			
LDNO 132kV: HV Medium Non-Domestic		5-8	0.385	0.023		69.83			
LDNO 132kV: LV Network Domestic		-	2.528	0.279	0.037	0.63			
LDNO 132kV: LV Network Non-Domestic Non-CT		-	2.250	0.246	0.033	0.63			
LDNO 132kV: LV HH Metered		0	1.706	0.175	0.023	2.42	0.61	0.058	0.61
LDNO 132kV: LV Sub HH Metered		0	2.135	0.203	0.026	11.82	0.92	0.067	0.92
LDNO 132kV: HV HH Metered		0	1.786	0.146	0.019	30.66	1.03	0.049	1.03
LDNO 132kV: NHH UMS category A		8	0.559						
LDNO 132kV: NHH UMS category B		1	0.627						
LDNO 132kV: NHH UMS category C		1	0.904						
LDNO 132kV: NHH UMS category D		1	0.528						
LDNO 132kV: LV UMS (Pseudo HH Metered)		0	6.045	0.515	0.324				
LDNO 132kV: LV Generation NHH or Aggregate HH		8	-0.295			0.00			
LDNO 132kV: LV Sub Generation NHH		8	-0.277			0.00			

Electricity North West - Effective from 01 April 2015 - Final LDNO tariffs

Time Bands for Half Hourly Metered Properties			
Time periods	Red Time Band	Amber Time Band	Green Time Band
Monday to Friday (Including Bank Holidays) All Year	16:00 to 19:00		
Monday to Friday (Including Bank Holidays) All Year		09:00 to 16:00 19:00 to 20:30	
Monday to Friday (Including Bank Holidays) All Year			00.00 - 09.00 20.30 - 24.00
Saturday and Sunday All Year		16:00 to 19:00	00.00 - 16.00 19.00 - 24.00
Notes	All the above times are in UK Clock time		

Time Bands for Half Hourly Unmetered Properties			
	Black Time Band	Yellow Time Band	Green Time Band
Monday to Friday (Including Bank Holidays) March to October Inclusive		09.00 - 20.30	00.00 - 09.00 20.30 - 24.00
Monday to Friday (Including Bank Holidays) Nov to Feb Inclusive	16:00 to 19:00	09:00 - 16:00 19:00 - 20:30	00.00 - 09.00 20.30 - 24.00
Saturday and Sunday		16:00 to 19:00	00.00 - 16.00 19.00 - 24.00
Notes	All the above times are in UK Clock time		

	Unique billing identifier	PCs	Unit rate 1 p/kWh (red/black)	Unit rate 2 p/kWh (amber/yellow)	Unit rate 3 p/kWh (green)	Fixed charge p/MPAN/day	Capacity charge p/kVA/day	Reactive power charge p/kVAh	Excess capacity charge p/kVA
LDNO 132kV: LV Generation Intermittent		0	-0.295			0.00		0.069	
LDNO 132kV: LV Generation Non-Intermittent		0	-2.179	-0.267	-0.036	0.00		0.069	
LDNO 132kV: LV Sub Generation Intermittent		0	-0.277			0.00		0.065	
LDNO 132kV: LV Sub Generation Non-Intermittent		0	-2.072	-0.244	-0.033	0.00		0.065	
LDNO 132kV: HV Generation Intermittent		0	-0.289			3.28		0.069	
LDNO 132kV: HV Generation Non-Intermittent		0	-2.238	-0.238	-0.032	3.28		0.069	
LDNO 0000: Domestic Unrestricted		1	0.156			0.23			
LDNO 0000: Domestic Two Rate		2	0.155	0.013		0.23			
LDNO 0000: Domestic Off Peak (related MPAN)		2	0.017						
LDNO 0000: Small Non Domestic Unrestricted		3	0.135			0.23			
LDNO 0000: Small Non Domestic Two Rate		4	0.140	0.011		0.23			
LDNO 0000: Small Non Domestic Off Peak (related MPAN)		4	0.013						
LDNO 0000: LV Medium Non-Domestic		5-8	0.142	0.011		1.54			
LDNO 0000: LV Sub Medium Non-Domestic		5-8	0.182	0.013		6.17			
LDNO 0000: HV Medium Non-Domestic		5-8	0.138	0.008		25.06			
LDNO 0000: LV Network Domestic		-	0.907	0.100	0.013	0.23			
LDNO 0000: LV Network Non-Domestic Non-CT		-	0.807	0.088	0.012	0.23			
LDNO 0000: LV HH Metered		0	0.612	0.063	0.008	0.87	0.22	0.021	0.22
LDNO 0000: LV Sub HH Metered		0	0.766	0.073	0.009	4.24	0.33	0.024	0.33
LDNO 0000: HV HH Metered		0	0.641	0.053	0.007	11.00	0.37	0.018	0.37
LDNO 0000: NHH UMS category A		8	0.201						
LDNO 0000: NHH UMS category B		1	0.225						
LDNO 0000: NHH UMS category C		1	0.325						
LDNO 0000: NHH UMS category D		1	0.189						
LDNO 0000: LV UMS (Pseudo HH Metered)		0	2.170	0.185	0.116				
LDNO 0000: LV Generation NHH or Aggregate HH		8	-0.106			0.00			
LDNO 0000: LV Sub Generation NHH		8	-0.099			0.00			
LDNO 0000: LV Generation Intermittent		0	-0.106			0.00		0.025	
LDNO 0000: LV Generation Non-Intermittent		0	-0.782	-0.096	-0.013	0.00		0.025	
LDNO 0000: LV Sub Generation Intermittent		0	-0.099			0.00		0.023	
LDNO 0000: LV Sub Generation Non-Intermittent		0	-0.743	-0.088	-0.012	0.00		0.023	
LDNO 0000: HV Generation Intermittent		0	-0.104			1.18		0.025	
LDNO 0000: HV Generation Non-Intermittent		0	-0.803	-0.085	-0.012	1.18		0.025	

Annex 5 – Schedule of Line Loss Factors

Electricity North West - Effective from 01 April 2015 - Final LLF Time Periods				
Time periods	Period 1	Period 2	Period 3	Period 4
Monday to Friday March to October			00:00 – 07:00	07:00 – 00:00
Monday to Friday November to February	16:00 – 19:00	07:00 – 16:00 19:00 – 00:00	00:00 – 07:00	
Saturday and Sunday All Year			00:00 – 07:00	07:00 – 00:00
Notes	All the above times are in UK Clock time			

Generic demand and generation LLFs					
Metered voltage, respective periods and associated LLFCs					
Metered voltage	Period 1	Period 2	Period 3	Period 4	Associated LLFC
Low-voltage network	1.107	1.095	1.082	1.090	11, 31, 41, 51, 61, 81, 91, 131, 161, 171, 191, 241, 431, 441, 451, 481, 511, 531, 581, 591, 631, 661, 751, 761, 771, 781, 791, 801, 811, 961, 971, 981
Low-voltage substation	1.054	1.051	1.046	1.049	242, 432, 482, 752, 802, 962, 972, 982
High-voltage network	1.040	1.037	1.030	1.035	483, 753, 803, 973, 983
High-voltage substation	1.028	1.026	1.022	1.024	109, 119, 129, 139, 149, 159, 169, 179, 189, 199, 209, 219, 229, 239, 249, 259, 269, 289, 299, 309, 319, 329, 339, 349, 359, 369, 379, 389, 419, 439, 459, 469, 479, 489, 499, 509, 519, 529
33kV generic	1.022	1.020	1.017	1.019	
132kV to 33k generic	1.015	1.014	1.012	1.014	
132kV generic	1.010	1.009	1.007	1.009	

EHV site specific LLFs					
Demand					
Site	Period 1	Period 2	Period 3	Period 4	Associated LLFC
Site 1	1.039	1.039	1.039	1.039	610
Site 2	1.002	1.002	1.002	1.002	500
Site 3	1.015	1.015	1.015	1.015	650
Site 4	1.032	1.032	1.032	1.032	660
Site 5	1.034	1.034	1.034	1.034	640
Site 6	1.090	1.090	1.090	1.090	700
Site 7	1.032	1.032	1.032	1.032	900
Site 8	1.009	1.009	1.009	1.009	670
Site 9	1.006	1.006	1.006	1.006	320
Site 10	1.018	1.018	1.018	1.018	850
Site 11	1.015	1.015	1.015	1.015	450
Site 12	1.000	1.000	1.000	1.000	460
Site 13	1.005	1.005	1.005	1.005	680
Site 14	1.008	1.008	1.008	1.008	520
Site 15	1.024	1.024	1.024	1.024	510
Site 16	1.014	1.014	1.014	1.014	530
Site 17	1.017	1.017	1.017	1.017	540
Site 18	1.051	1.051	1.051	1.051	550
Site 19	1.007	1.007	1.007	1.007	810
Site 20	1.012	1.012	1.012	1.012	830

Site 21	1.000	1.000	1.000	1.000	960
Site 22	1.000	1.000	1.000	1.000	370
Site 23	1.000	1.000	1.000	1.000	410
Site 24	1.000	1.000	1.000	1.000	430
Site 25	1.000	1.000	1.000	1.000	340
Site 26	1.000	1.000	1.000	1.000	480
Site 27	1.000	1.000	1.000	1.000	600
Site 28	1.000	1.000	1.000	1.000	980
Site 29	1.000	1.000	1.000	1.000	280
Site 30	1.000	1.000	1.000	1.000	260
Site 31	1.005	1.005	1.005	1.005	180
Site 32	1.000	1.000	1.000	1.000	200
Site 33	1.000	1.000	1.000	1.000	140
Site 34	1.000	1.000	1.000	1.000	160
Site 35	1.008	1.008	1.008	1.008	950
Site 36	1.010	1.010	1.010	1.010	910
Site 37	1.002	1.002	1.002	1.002	920
Site 38	1.167	1.167	1.167	1.167	570
Site 69	1.000	1.000	1.000	1.000	110
Site 70	1.000	1.000	1.000	1.000	220
Site 71	1.000	1.000	1.000	1.000	80
Site 72	1.000	1.000	1.000	1.000	40
Site 73	1.000	1.000	1.000	1.000	60
Site 74	1.000	1.000	1.000	1.000	68
Site 75	1.000	1.000	1.000	1.000	20
Site 76	1.000	1.000	1.000	1.000	10
Site 77	1.000	1.000	1.000	1.000	MSID 7016
Site 78	0.995	0.995	0.995	0.995	MSID 7039,7040
Site 79	0.998	0.998	0.998	0.998	MSID 7107
Site 84	1.010	1.010	1.010	1.010	MSID 2037,2038
Site 85	1.013	1.013	1.013	1.013	MSID 7156
Site 86	1.008	1.008	1.008	1.008	MSID 0437

EHV sites specific LLFs					
Generation					
Site	Period 1	Period 2	Period 3	Period 4	Associated LLFC
Site 12	1.000	1.000	1.000	1.000	470
Site 13	0.991	0.991	0.991	0.991	690
Site 14	1.000	1.000	1.000	1.000	730
Site 15	1.000	1.000	1.000	1.000	720
Site 16	0.999	0.999	0.999	0.999	770
Site 17	0.980	0.980	0.980	0.980	740
Site 18	1.001	1.001	1.001	1.001	750
Site 19	1.001	1.001	1.001	1.001	820
Site 20	0.998	0.998	0.998	0.998	840
Site 21	0.994	0.994	0.994	0.994	970
Site 22	0.989	0.989	0.989	0.989	360
Site 23	0.991	0.991	0.991	0.991	420
Site 24	0.993	0.993	0.993	0.993	440
Site 25	0.984	0.984	0.984	0.984	350
Site 26	0.995	0.995	0.995	0.995	490
Site 27	0.999	0.999	0.999	0.999	590
Site 28	0.995	0.995	0.995	0.995	990
Site 29	0.989	0.989	0.989	0.989	290

Site 30	0.995	0.995	0.995	0.995	270
Site 31	0.998	0.998	0.998	0.998	190
Site 32	1.000	1.000	1.000	1.000	210
Site 33	0.994	0.994	0.994	0.994	150
Site 34	1.010	1.010	1.010	1.010	170
Site 69	1.004	1.004	1.004	1.004	120
Site 70	1.012	1.012	1.012	1.012	230
Site 71	0.989	0.989	0.989	0.989	90
Site 72	1.017	1.017	1.017	1.017	50
Site 73	0.996	0.996	0.996	0.996	70
Site 74	0.996	0.996	0.996	0.996	78
Site 75	0.992	0.992	0.992	0.992	30
Site 76	0.996	0.996	0.996	0.996	100

Annex 6 - New Designated EHV Properties. Addendum to Schedule of Charges for use of the Distribution System by Designated EHV Properties (including LDNOs with Designated EHV Properties/end-users).

Electricity North West - Effective from 01 April 2015 - Final new designated EHV charges														
Import Unique Identifier	Import MPANs/MSIDs	Import LLFC	Export Unique Identifier	Export LLFC	Export MPANs/MSIDs	Name	Import super-red unit rate p/kWh	Import fixed charge p/day	Import capacity rate p/kVA/day	Import exceeded capacity rate p/kVA/day	Export super-red unit rate p/kWh	Export fixed charge p/day	Export capacity rate p/kVA/day	Export exceeded capacity rate p/kVA/day
Tariff 131	1640000458483	088	Tariff 132	098	1640000458517	Site 89	0.384	9.16	4.89	4.89	0.00	1,373.69	0.07	0.07
			Tariff 133	217	1640000519728	Site 8						408.61	0.07	0.07
Tariff 134	1640000541732	187	Tariff 135	177	1640000541741	Site 90	0.438	4.52	4.12	4.12		391.42	0.07	0.07
Tariff 136	1640000541166	297	Tariff 137	287	1640000541175	Site 91	1.442	2.13	5.09	5.09		393.81	0.07	0.07
Tariff 138	1640000541148	277	Tariff 139	267	1640000541157	Site 92	0.438	18.36	5.60	5.60		1,835.96	0.07	0.07

Electricity North West - Effective from 01 April 2015 - Final new designated EHV line loss factors																
Import Unique Identifier	Import MPANs/MSIDs	Import LLFC	Export Unique Identifier	Export LLFC	Export MPANs/MSIDs	Name	Import LLF period 1	Import LLF period 2	Import LLF period 3	Import LLF period 4	Import LLF period 5	Export LLF period 1	Export LLF period 2	Export LLF period 3	Export LLF period 4	Export LLF period 5
Tariff 131	1640000458483	088	Tariff 132	098	1640000458517	Site 89	1.013	1.013	1.013	1.013	1.013	0.981	0.981	0.981	0.981	0.981
			Tariff 133	217	1640000519728	Site 8						1.000	1.000	1.000	1.000	1.000
Tariff 134	1640000541732	187	Tariff 135	177	1640000541741	Site 90	1.000	1.000	1.000	1.000	1.000	0.991	0.991	0.991	0.991	0.991
Tariff 136	1640000541166	297	Tariff 137	287	1640000541175	Site 91	1.000	1.000	1.000	1.000	1.000	0.995	0.995	0.995	0.995	0.995
Tariff 138	1640000541148	277	Tariff 139	267	1640000541157	Site 92	1.000	1.000	1.000	1.000	1.000	0.993	0.993	0.993	0.993	0.993